

# GERMAN HEAVY TANK Pz.Kpfw. VI, Ausf.E (Sd.Kfz. 181) Tiger I

Middle production version  
-Basic set

Niemiecki ciężki czołg Tiger I, pośrednia wersja  
- zestaw podstawowy  
1/16 scale update fit to Hobby Boss

**ABER**

**16 050**

WWW.ABER.NET.PL

Made in Poland © 2013

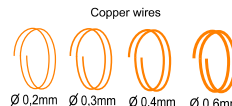
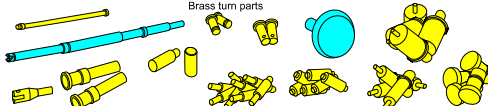
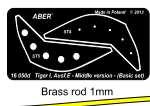
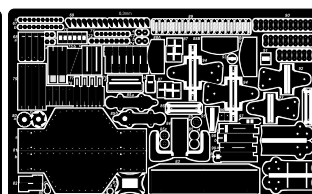
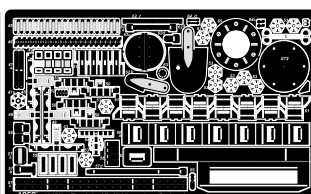
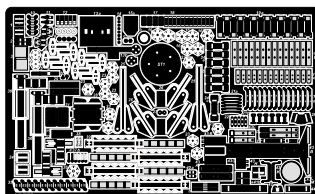

**WARNING**  
Any unauthorized copying, producing and reproducing of ABER company products, or any part thereof, is strictly prohibited and any such action establishes liability for a civil action and may give rise to criminal prosecution.

Please note that, for purpose of improvement ABER sets designs are subjects to change without notice. Proszę mieć na uwadze fakt, że zestawy ABER mogą ulec zmianie ze względu na ulepszenia, bez powiadomienia.

**OSTRZEŻENIE**  
Jakiegokolwiek kopiowanie, produkowanie i reprodukcja wyrobów firmy ABER bez zezwolenia, w całości lub części jest surowo zabronione. Powyższe działania powodują powstanie odpowiedzialności cywilnej oraz mogą spowodować wszczęcie postępowania karnego.

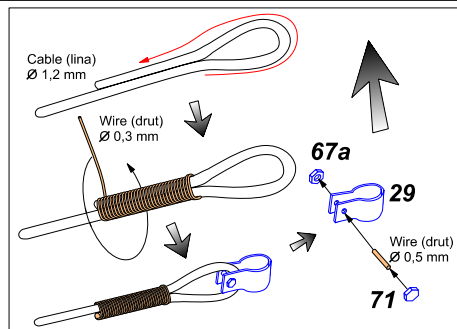
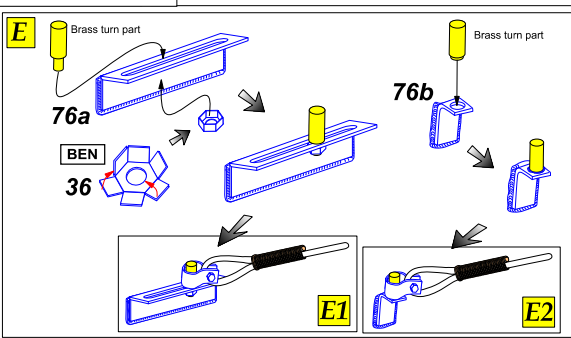
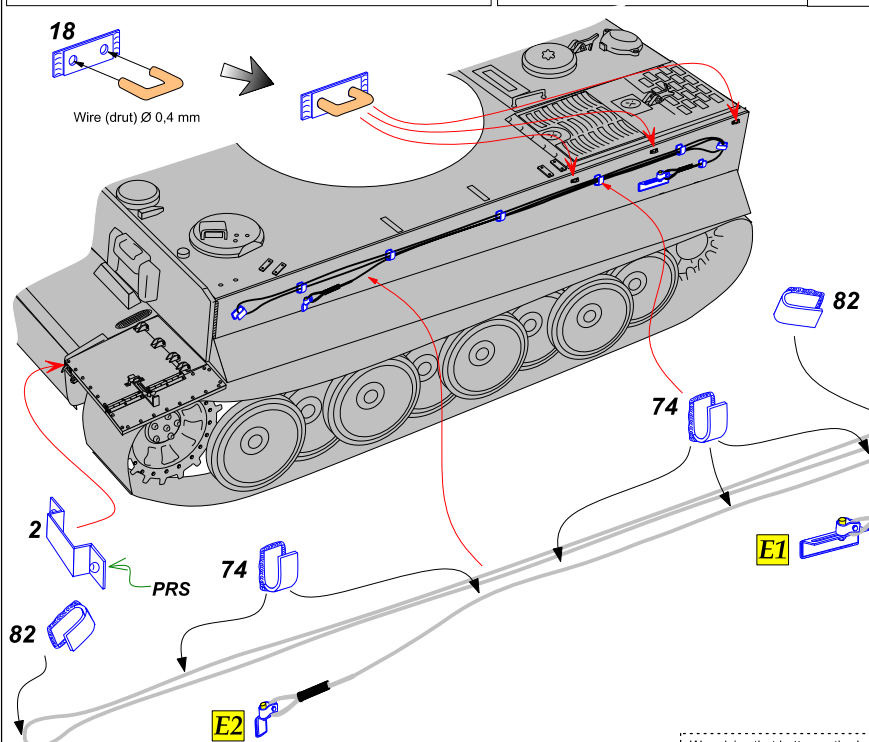
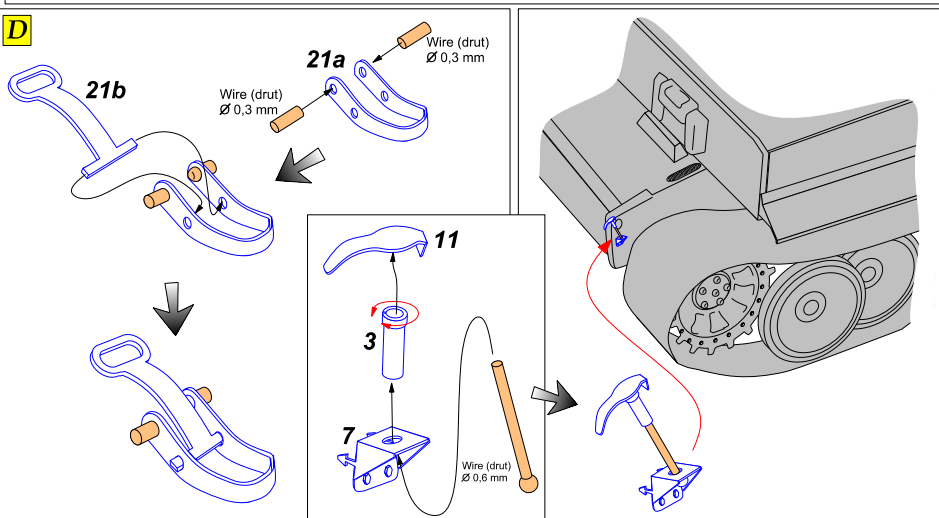
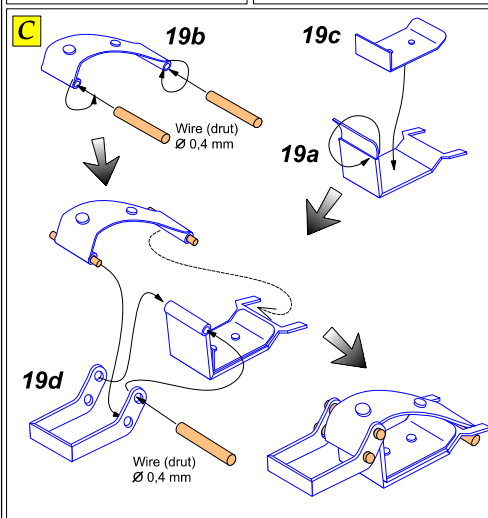
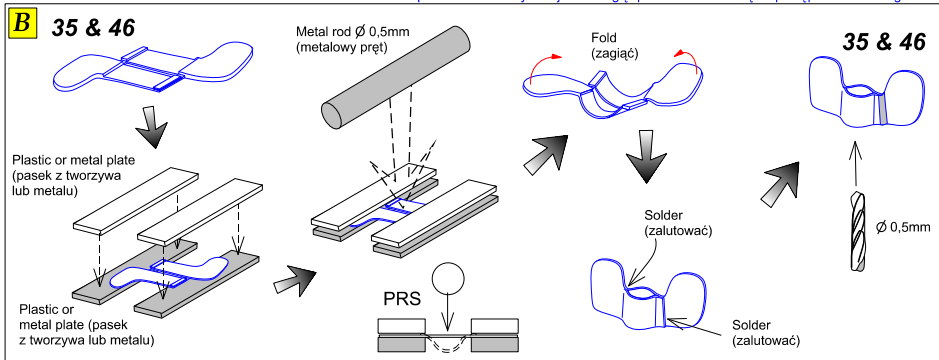
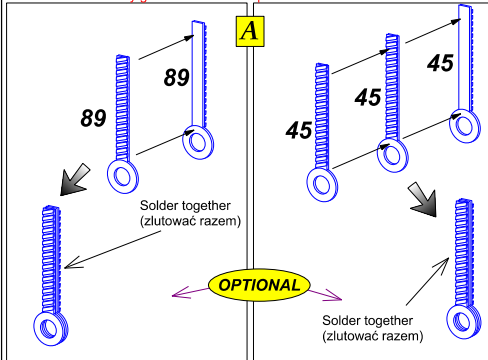

We advise that better method to join metal to metal is soldering. Use ABER soldering solution AF20 (dodajemy łączenie części metalowych za pomocą lutownia. Zastosuj nasz topnik AF20)

- Separately sold (oddzielnie w sprzedaży):
- 16 004 -Front fenders Tiger I, Ausf.E (Early/Late vesion)
  - 16 006 -Side fenders Tiger I, Ausf.E (Early/Late vesion)
  - 16 007 -Exhaust covers Tiger I, Ausf.E (Early/Late vesion)
  - 16 012 -8,8 cm Tiger I A/T Ammo with box
  - 16 032 -German 2 meter standard Antenna
  - 16 051 -Rear fenders Tiger I, Ausf.E (Late vesion)
  - 16 L-03 - German barrel for tank machine gun MG 34 with Panzermantel







