

BRITISH WWII FIGHTER 1:48 SCALE PLASTIC KIT



eduard

intro



In September 1941, a hitherto unknown German radial engine fighter appeared in the west European sky. The new airplane was superior to British fighters, most distressingly to the Spitfire Mk.V. The German design was soon recognized as the Focke-Wulf Fw 190A. The losses suffered by the RAF over western Europe rose rapidly and the crisis was serious enough that the RAF ceased the majority of daytime operations in November, 1941. The next attempt to resume these types of sorties was made in March 1942. Loss rates remained unacceptably high and the RAF was forced to stop ops once again. All this was thanks to the Focke-Wulf Fw 190A.

The first response to the new German weapon was the Spitfire Mk.VIII, but the design changes were so complex that initiating timely production was not possible.

In June, 1942, a German pilot landed by mistake on a British airfield delivering a completely intact Fw 190 fighter into RAF hands. Comparative trials between the Focke-Wulf and Spitfire Mk.V began almost immediately. These mock encounters confirmed the situation over the front – the chances of a British fighter surviving an encounter with the Fw 190 were slim.

The only British fighter aircraft deemed suitable to oppose them were the Spitfire Mk. VII and VIII powered by the Merlin 61 engine. As mentioned above these were some time away of being ready for series production.

The Spitfire Mk.VIII did not reach operational units until July, 1943. Thanks to their longer range they served in the Mediterranean Theatre of Operations and were flown by RAF as well as USAAF pilots and were deployed by the RAF against Japanese armed forces in India and Burma. The Royal Australian Air Force fought against Japanese forces using the Mk.VIII in the Pacific area as well.

There were three sub-versions – F Mk.VIII powered by the Merlin 63 engine, LF Mk.VIII powered by the Merlin 66 and the HF Mk.VIII powered by the Merlin 70. In comparison with the Spitfire Mk.IX, they had a retractable tailwheel and smaller ailerons. Three types of wingtips were utilized on this version of the Spitfire.

The Mk. VIII was the third most numerous version of the Spitfire with 1,658 examples built.

úvodem

V září 1941 se na evropské obloze objevil dosud neznámý německý stíhací letoun poháněný hvězdicovým motorem. Nová stíhačka měla nad britskými, zejména Spitfirem Mk.V, zřetelnou převahu. V německé konstrukci byl záhy rozpoznán Focke-Wulf Fw 190 A. Ztráty RAF nad západní Evropou začaly rychle narůstat až to té míry, že britské letectvo muselo v listopadu 1941 zastavit většinu denních operací nad evropským kontinentem. Pokus o spuštění tohoto typu bojových letů byl uskutečněn v březnu 1942. Počty ztrát však byly opět neúnosné, což opět vedlo k jejich zastavení. Vše díky Focke-Wulfům Fw 190 A.

Prvním pokusem o odpověď na novou německou zbraň se stal Spitfire Mk.VIII, avšak komplexní přístup ke změnám konstrukce letounu způsobil, že nebylo možné jej dostat do sériové výroby v dostatečně blízkém časovém horizontu.

V červnu 1942 přistál jeden z německých pilotů omylem na britském letišti a předal tak do britských rukou nepoškozený Fw 190 A. Srovnávací zkoušky Focke-Wulfu a Spitfiru Mk.V začaly téměř neprodleně. Cvičné souboje plně potvrdily situaci na frontě – šance britské stíhačky přestat setkání s Fw 190 bez úhony nebyly vysoké.

Jediné britské stíhačky schopné postavit se plnohodnotně německému typu byly Spitfiry Mk.VII a Mk.VIII poháněné motorem Merlin 61. Jak však bylo poznamenáno výše, nedalo se čekat, že v dohledné době dospějí do fáze sériové výroby. Na evropském bojišti se nakonec prosadila verze Mk.IX, která se dostala do sériové výroby dříve, než Mk.VIII.

Spitfiry Mk.VIII se k bojovým jednotkám dostaly v červenci 1943. Delší dolet je předurčoval k nasazení ve Středomoří. Zde je používala RAF, ale také USAAF. Do bojů se zapojily také v Indii a Barmě. Neméně známé je také nasazení v Pacifiku, v řadách australského letectva proti japonským ozbrojeným silám.

Osmičky opouštěly montážní linky ve třech základních provedeních – F Mk.VIII s motorem Merlin 63, LF Mk.VIII s motorem Merlin 66 a HF Mk.VIII s motorem Merlin 70. Od Spitfiru Mk.IX se na první pohled odlišovaly zatahovací ostruhou a kratším rozpětím křidélek. Křídlo mohlo dostat dle potřeby různé koncové oblouky.

Tato verze se stala třetí nejpočetnější verzí Spitfiru s 1658 postavenými kusy.

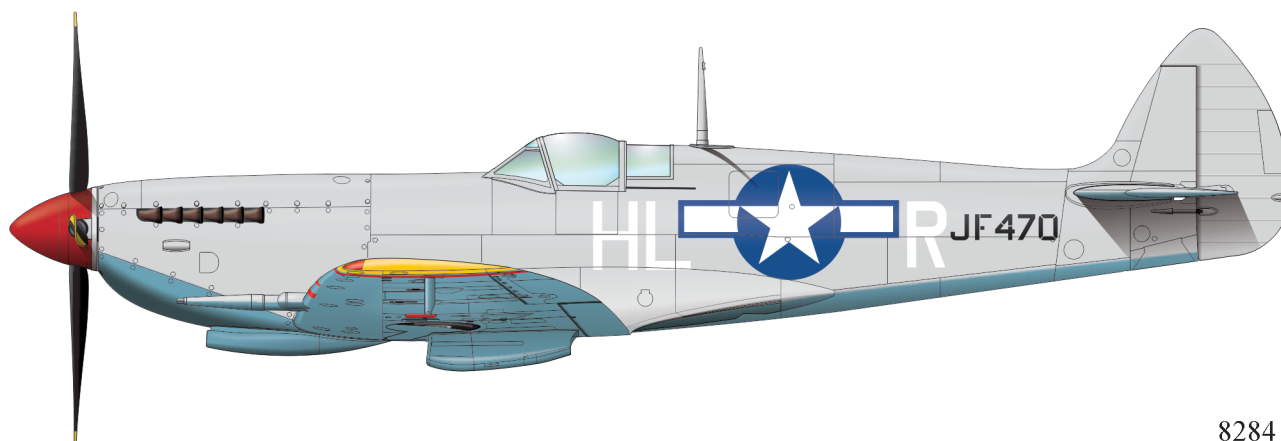

ATTENTION



UPOZORNĚNÍ



ACHTUNG



ATTENTION



注意



Carefully read instruction sheet before assembling. When you use glue or paint, do not use near open flame and use in well ventilated room. Keep out of reach of small children. Children must not be allowed to suck any part, or pull vinyl bag over the head.



Před započítím stavby si pečlivě prostudujte stavební návod. Při používání barev a lepidla pracujte v dobře větrané místnosti. Lepidla ani barvy nepoužívejte v blízkosti otevřeného ohně. Model není určen malým dětem, mohlo by dojít k požití drobných dílů.

INSTRUCTION SIGNS * INSTR. SYMBOL * INSTRUKTION SINNBILDEN * SYMBOLES * 記号の説明

OPTIONAL
VOLBABEND
OHNOUTOPEN HOLE
VYVRTAT OTVORSYMMETRICAL ASSEMBLY
SYMETRICKÁ MONTÁŽREMOVE
ODŘÍZNOUTREVERSE SIDE
OTOČITAPPLY EDUARD MASK
AND PAINT
POUŽÍT EDUARD MASK
NABARVIT

PARTS



DÍLY



TEILE



PIÈCES



部品

PLASTIC PARTS

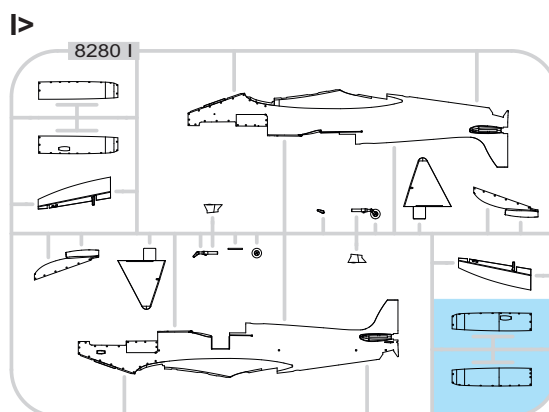
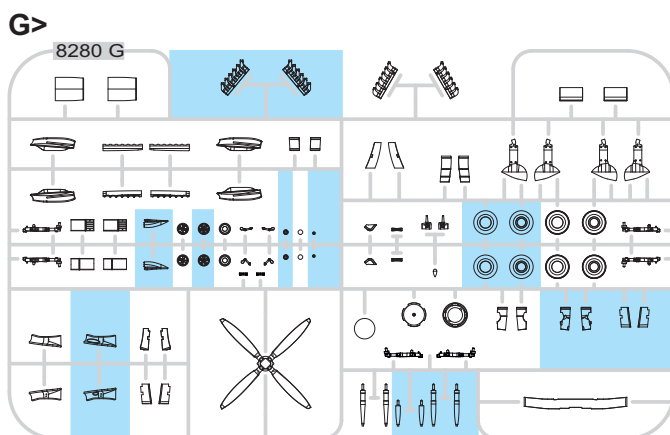
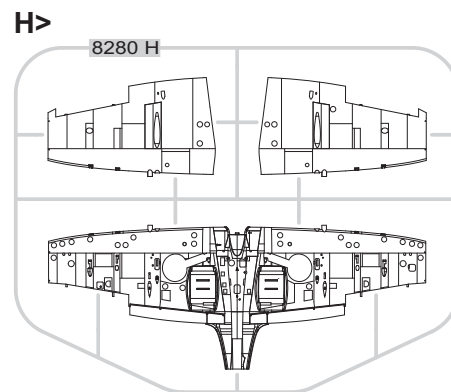
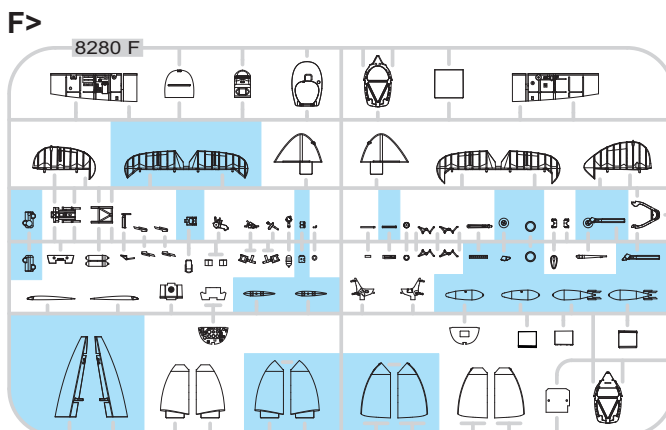
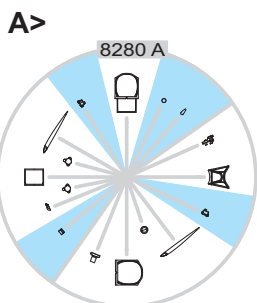
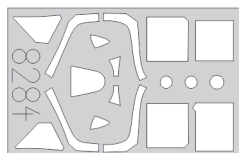
eduard
MASK

PE - PHOTO ETCHED DETAIL PARTS

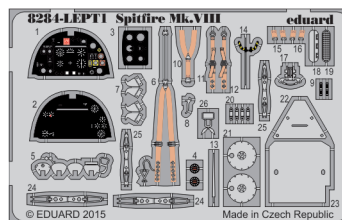

-Parts not for use. -Teile werden nicht verwendet. -Pièces à ne pas utiliser. -Tyto díly nepoužívejte při stavbě. - 使用しない部品

COLOURS



BARVY



FARBEN



PEINTURE



色

GSI Creos (GUNZE)		
AQUEOUS	Mr.COLOR	
H 4	C4	YELLOW
H 12	C33	FLAT BLACK
H 13	C3	FLAT RED
H 33	C81	RUSSET
H 51	C11	LIGHT GULL GRAY
H 71	C21	MIDDLE STONE
H 72	C369	DARK EARTH
H 73	C361	DARK GREEN
H 77	C137	TIRE BLACK
H 90	C47	CLEAR RED
H 94	C138	CLEAR GREEN

AQUEOUS	Mr.COLOR	
H 312	C312	GREEN
H 316	C316	WHITE
	C361	MEDIUM SEAGRAY
	C362	OCEAN GRAY
	C363	DARK GREEN
	C370	AZURE BLUE
Mr.METAL COLOR		
	MC214	DARK IRON
	MC218	ALUMINIUM
Mr.COLOR SUPER METALLIC		
	SM01	SUPER FINE SILVER
	SM06	CHROME SILVER

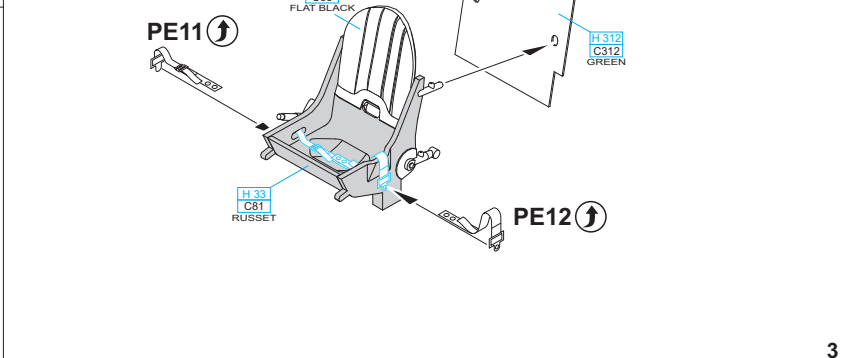
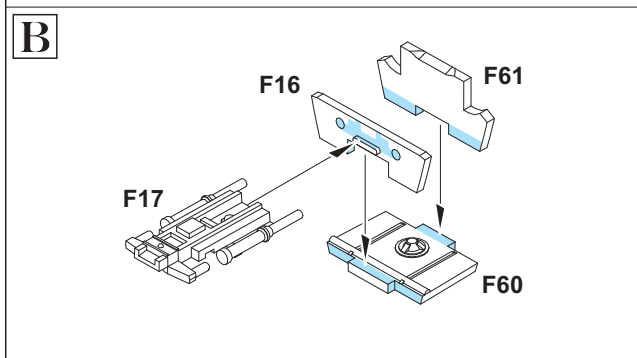
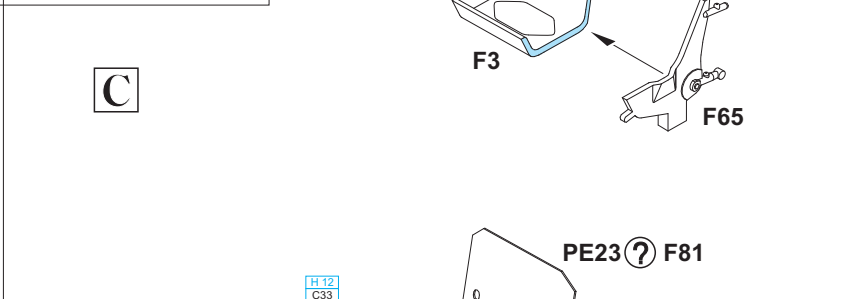
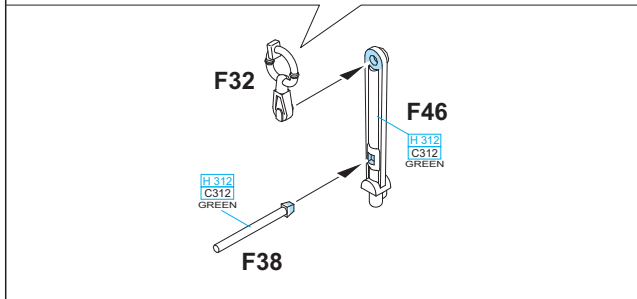
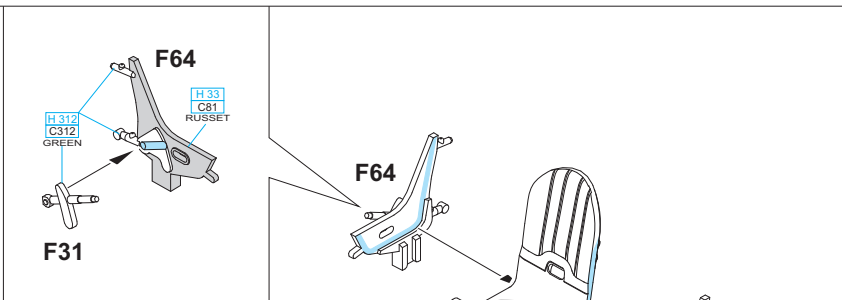
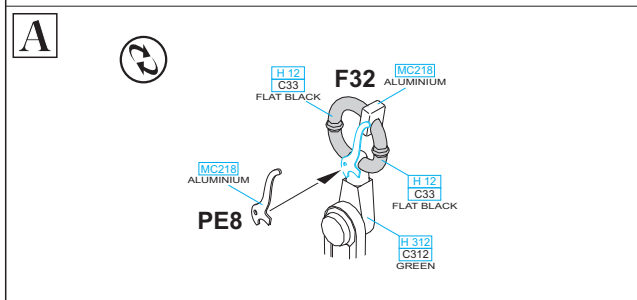
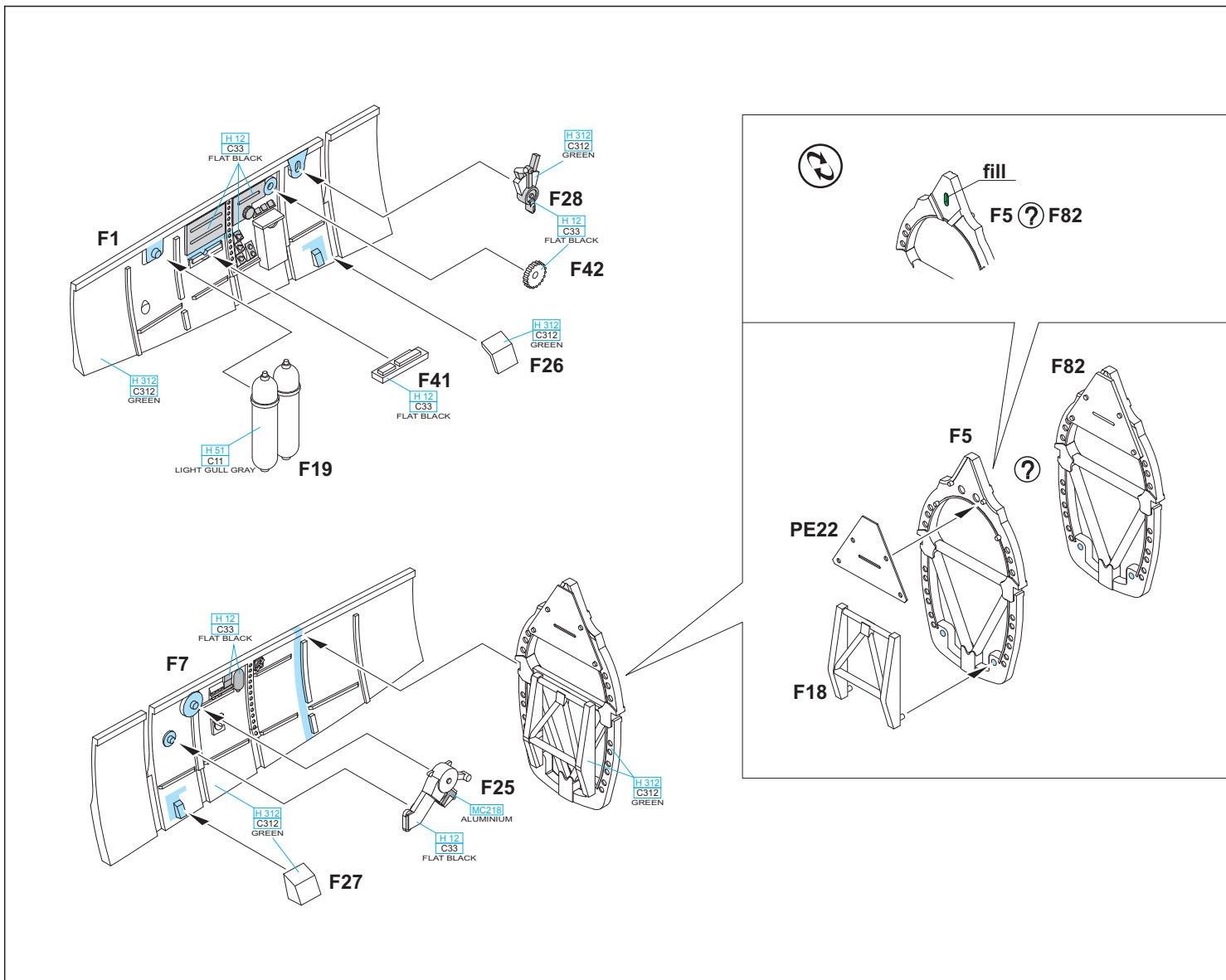

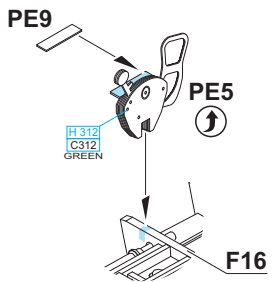
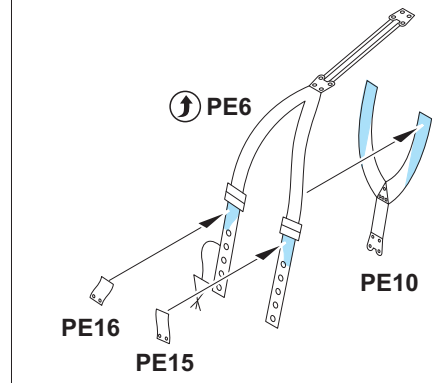
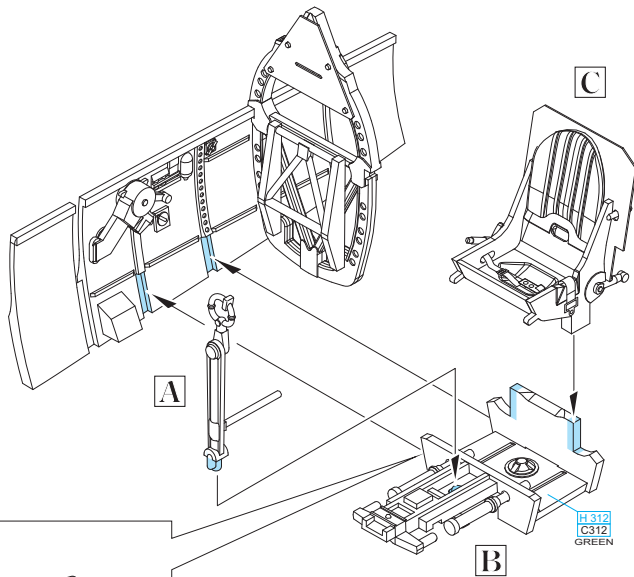

**OPTIONAL:
DECAL 28**

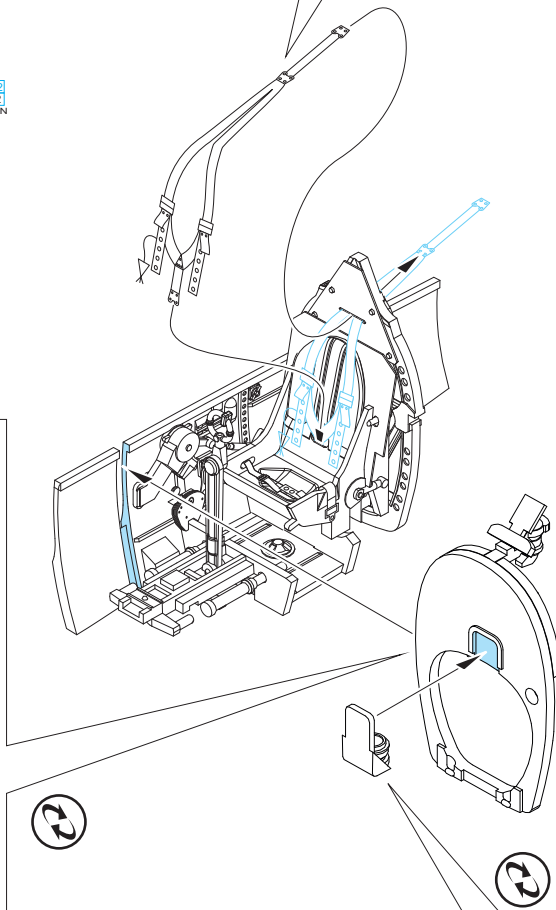
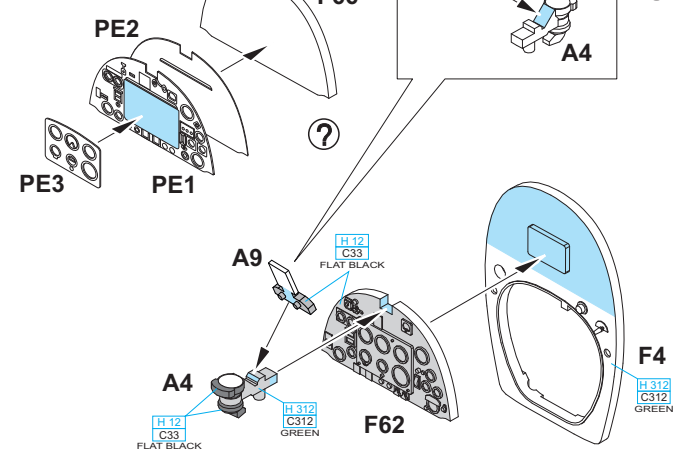

**OPTIONAL:
DECAL 47**

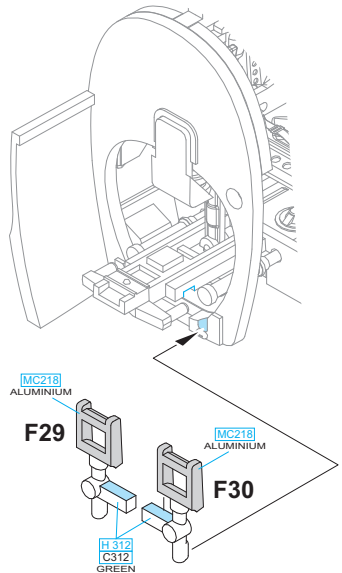
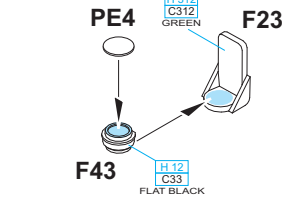

D

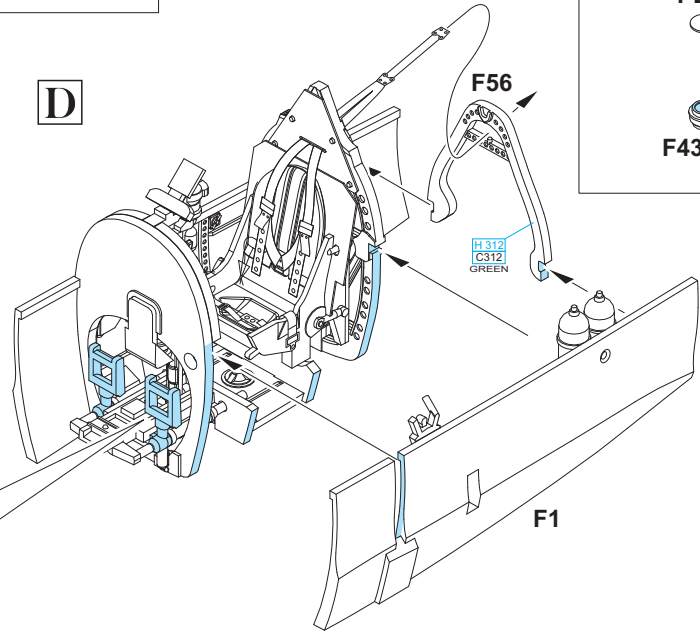

⑦ FOR CLOSED CANOPY ONLY

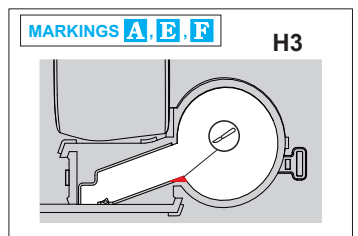
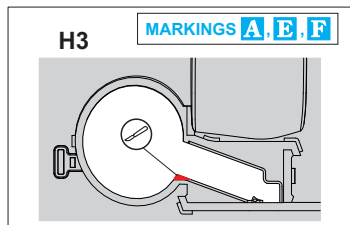
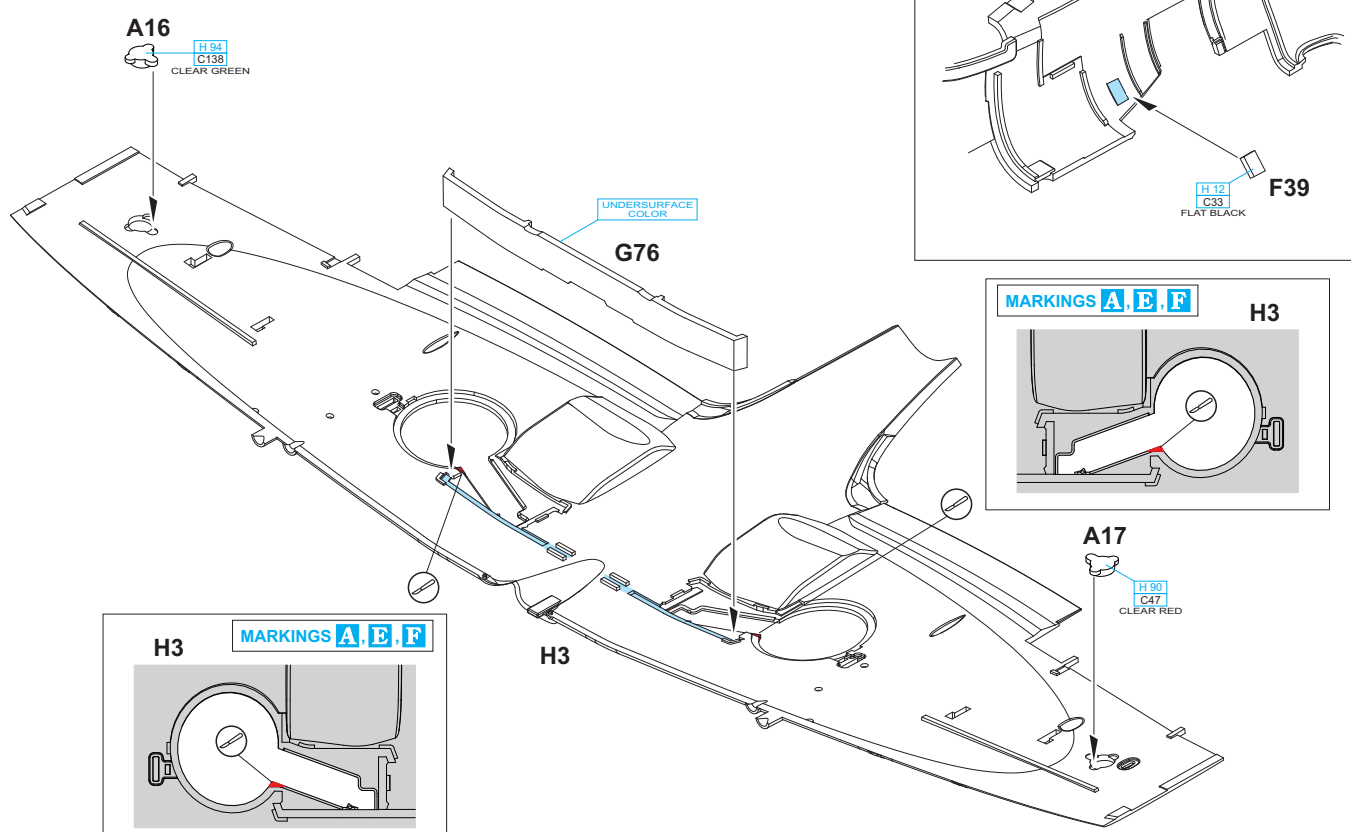
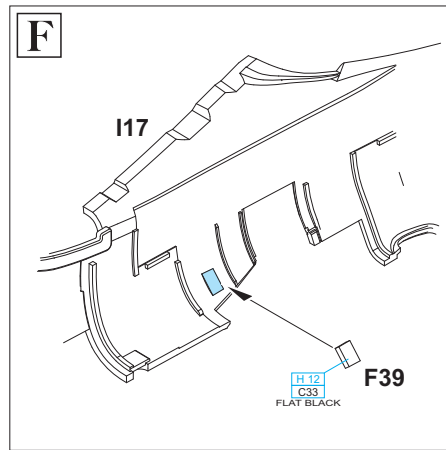
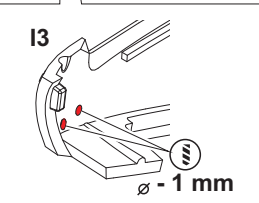
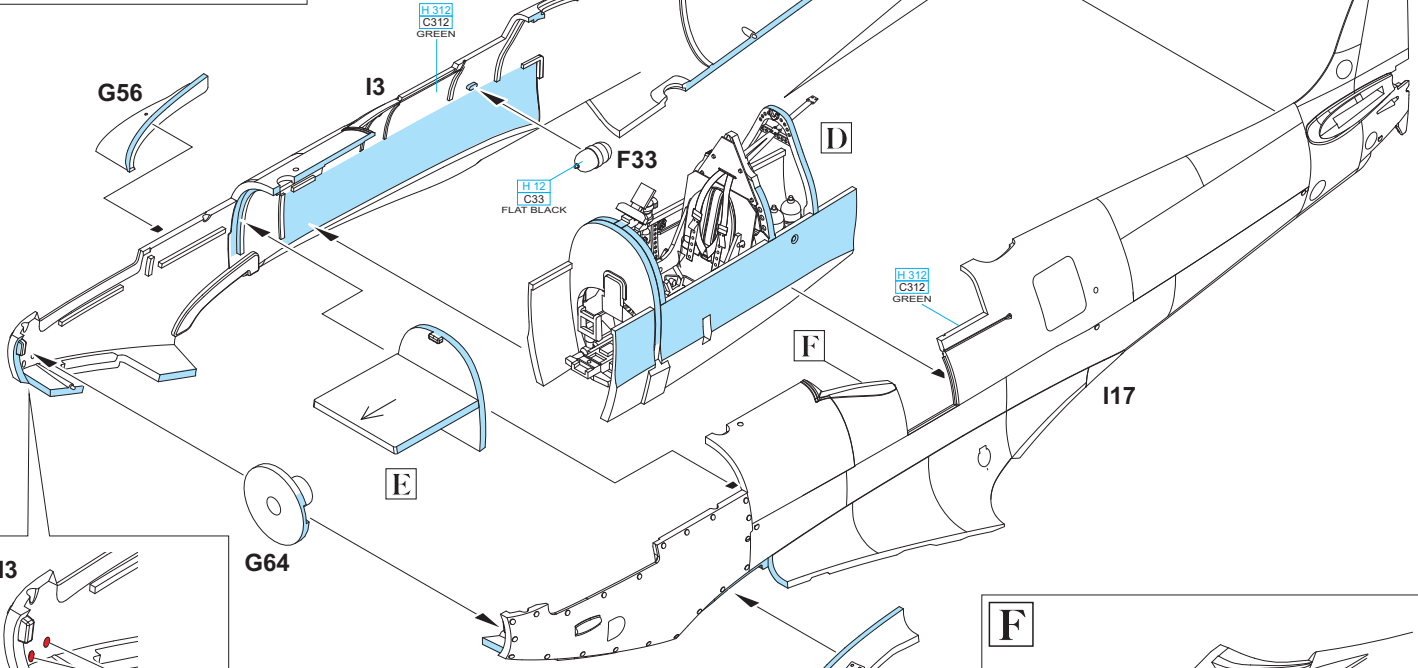
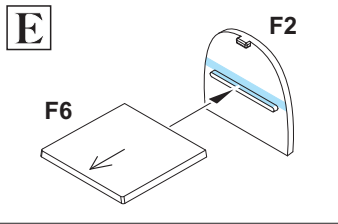
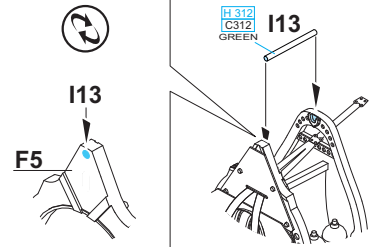
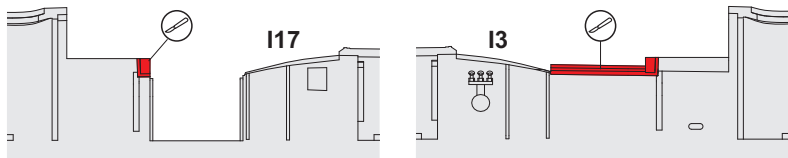

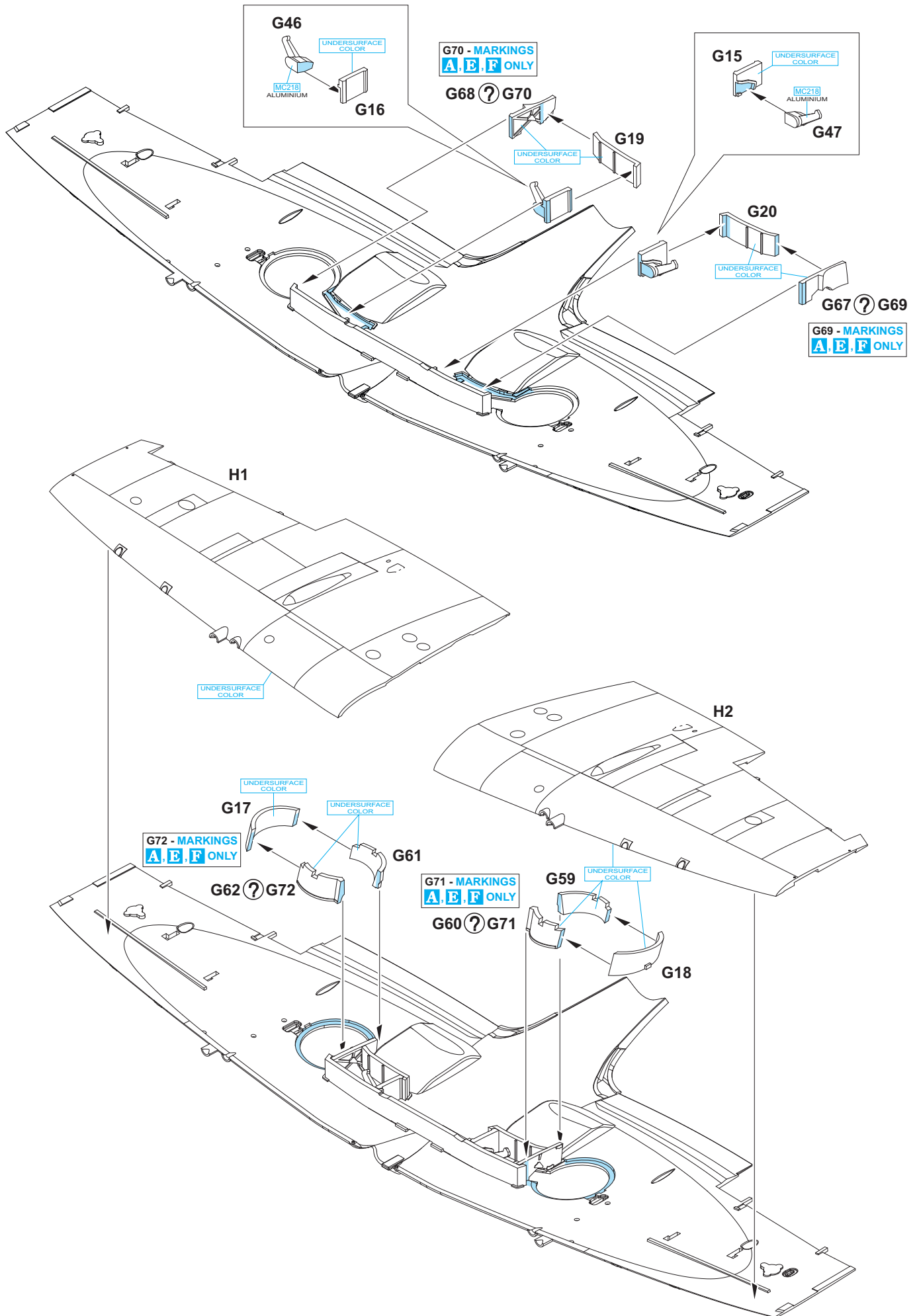

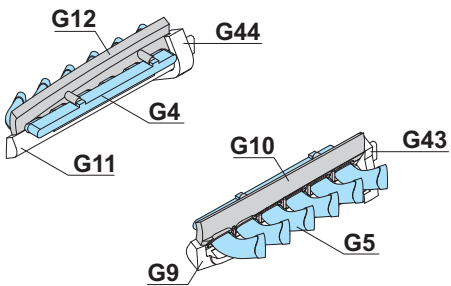
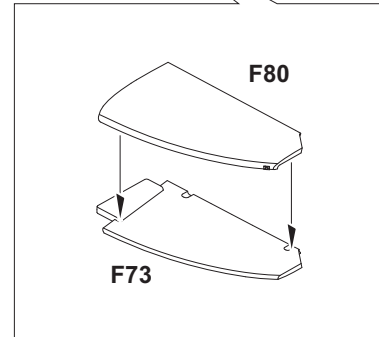
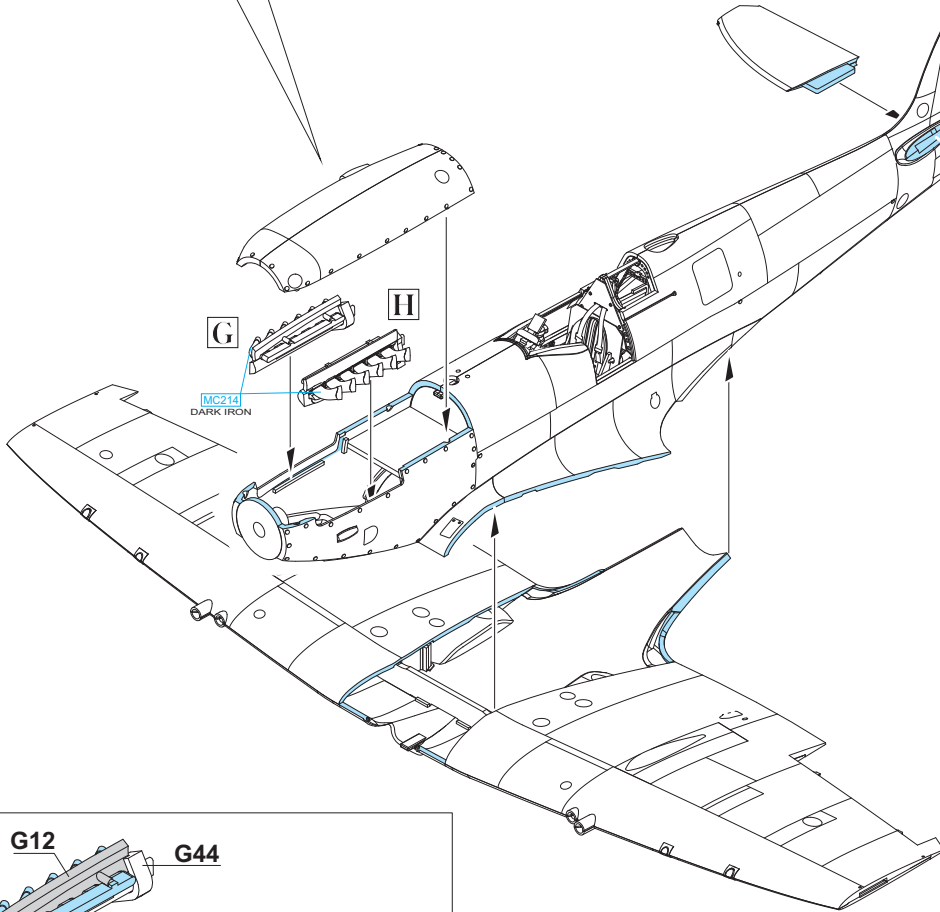
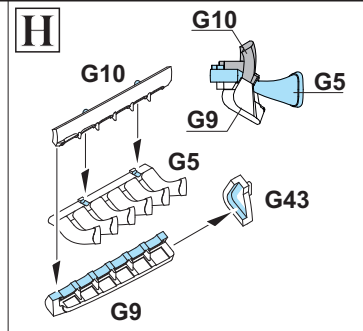
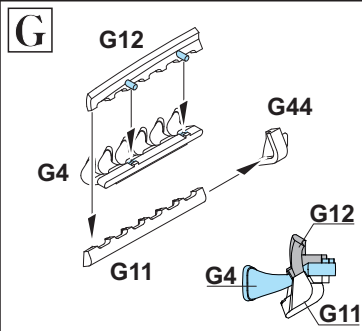
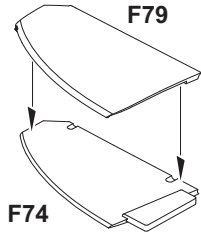
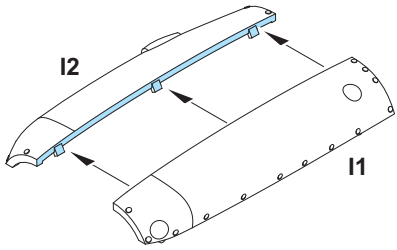

GLUE PARTS F52 & F53
ONE BY ONE

F8 - MARKINGS C, D

F13 - MARKINGS A, B, E, F

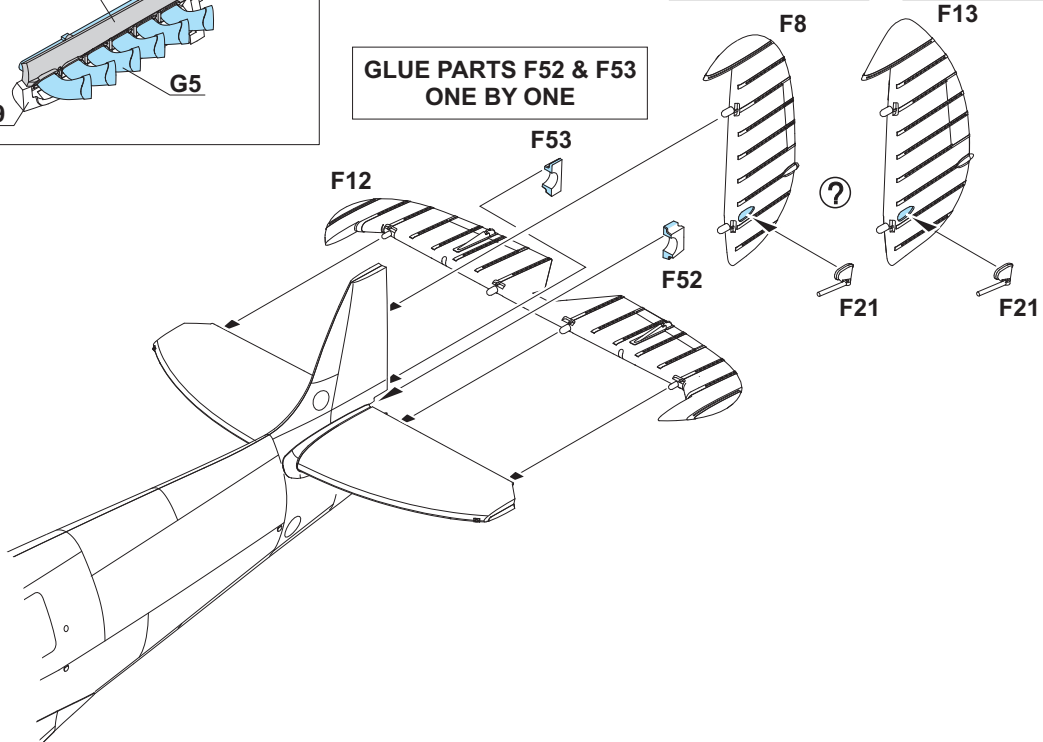

F11- MARKINGS **A, E, F**

F11

I4

?

I8

I8- MARKINGS **C, D**

?

H 94
C138
CLEAR GREEN

A7 ? F59

A7 ? F59 - MARKING **B**

A13 ? F58

A13 ? F58 - MARKING **B**

H 90
C47
CLEAR RED

I11

I11- MARKINGS **C, D**

F10

F10- MARKINGS **A, E, F**

PE18, PE19 - MARKINGS **A, B, C, D, E ONLY**

I9

PE19

PE18

I10

UNDERSURFACE
COLOR

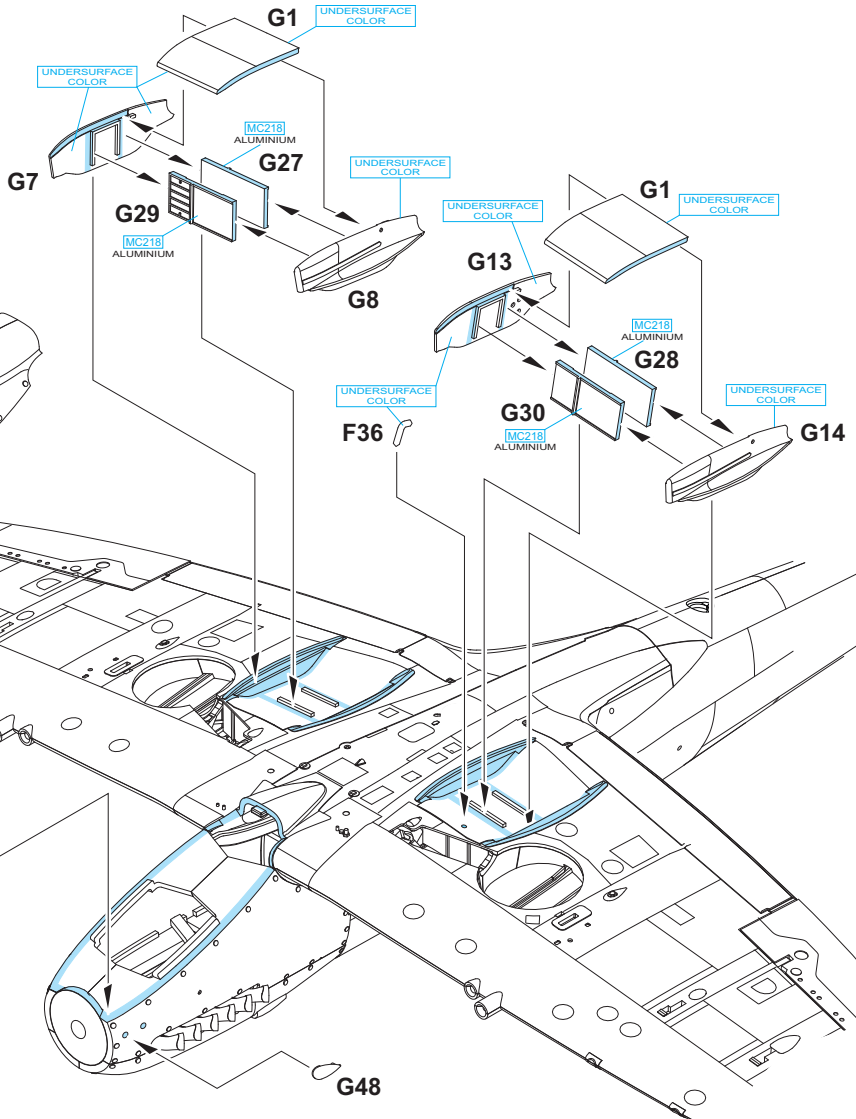

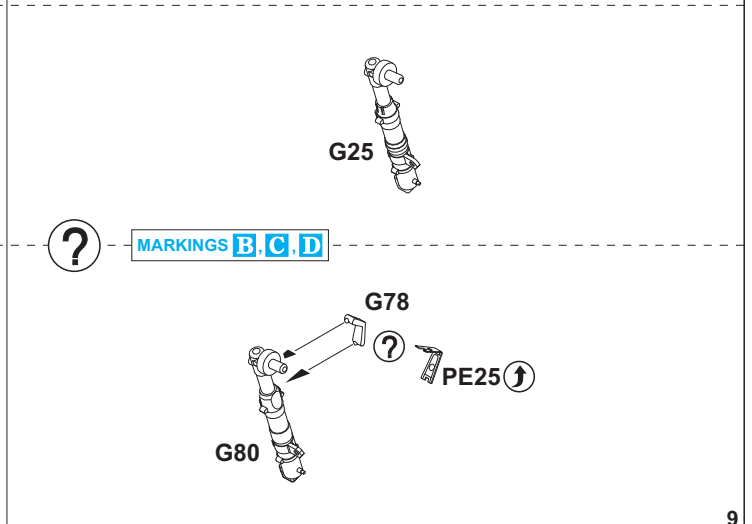
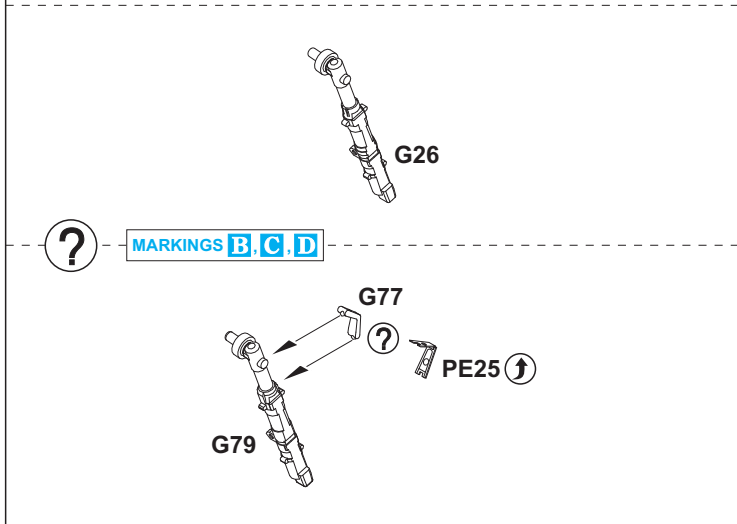
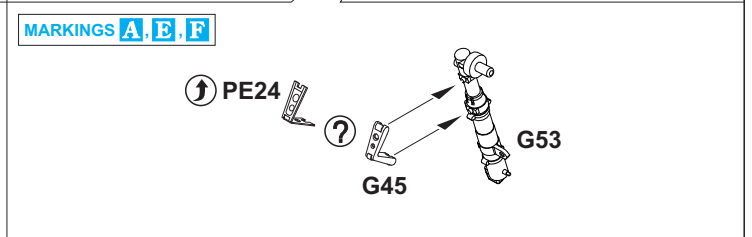
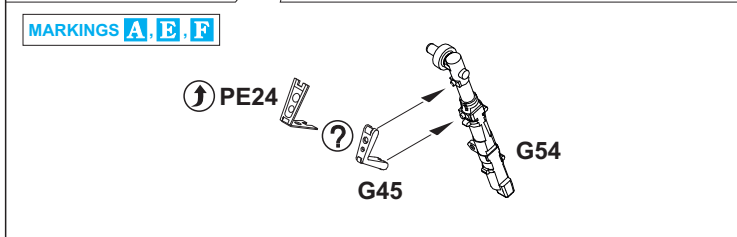
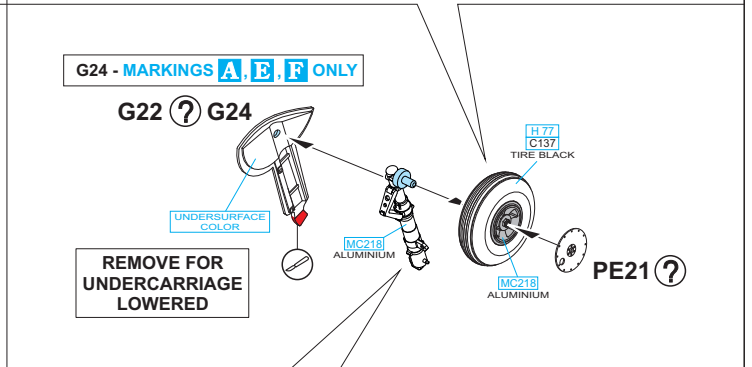
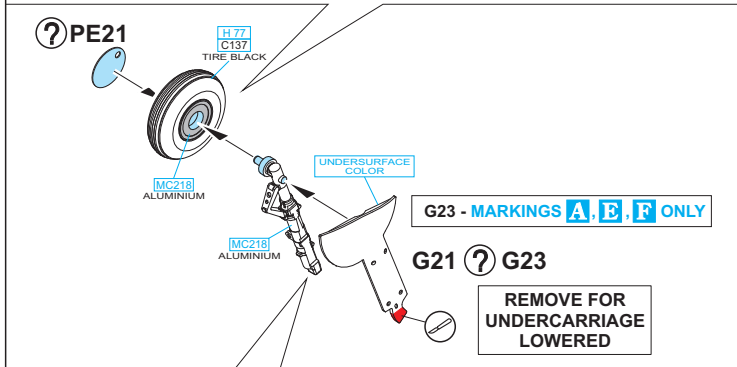
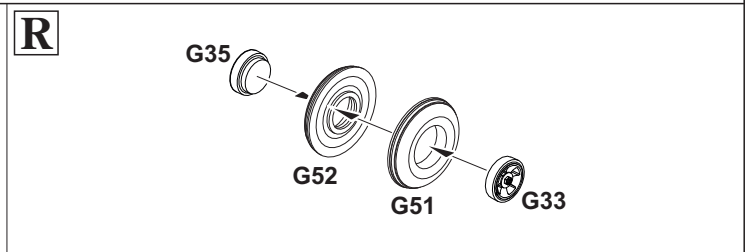
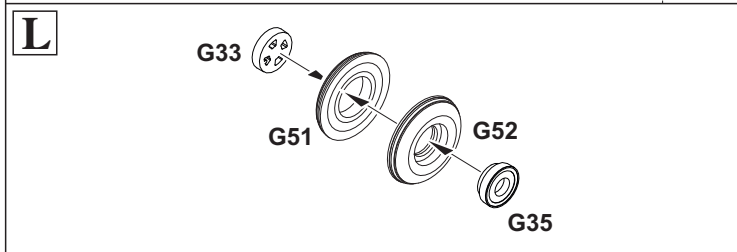
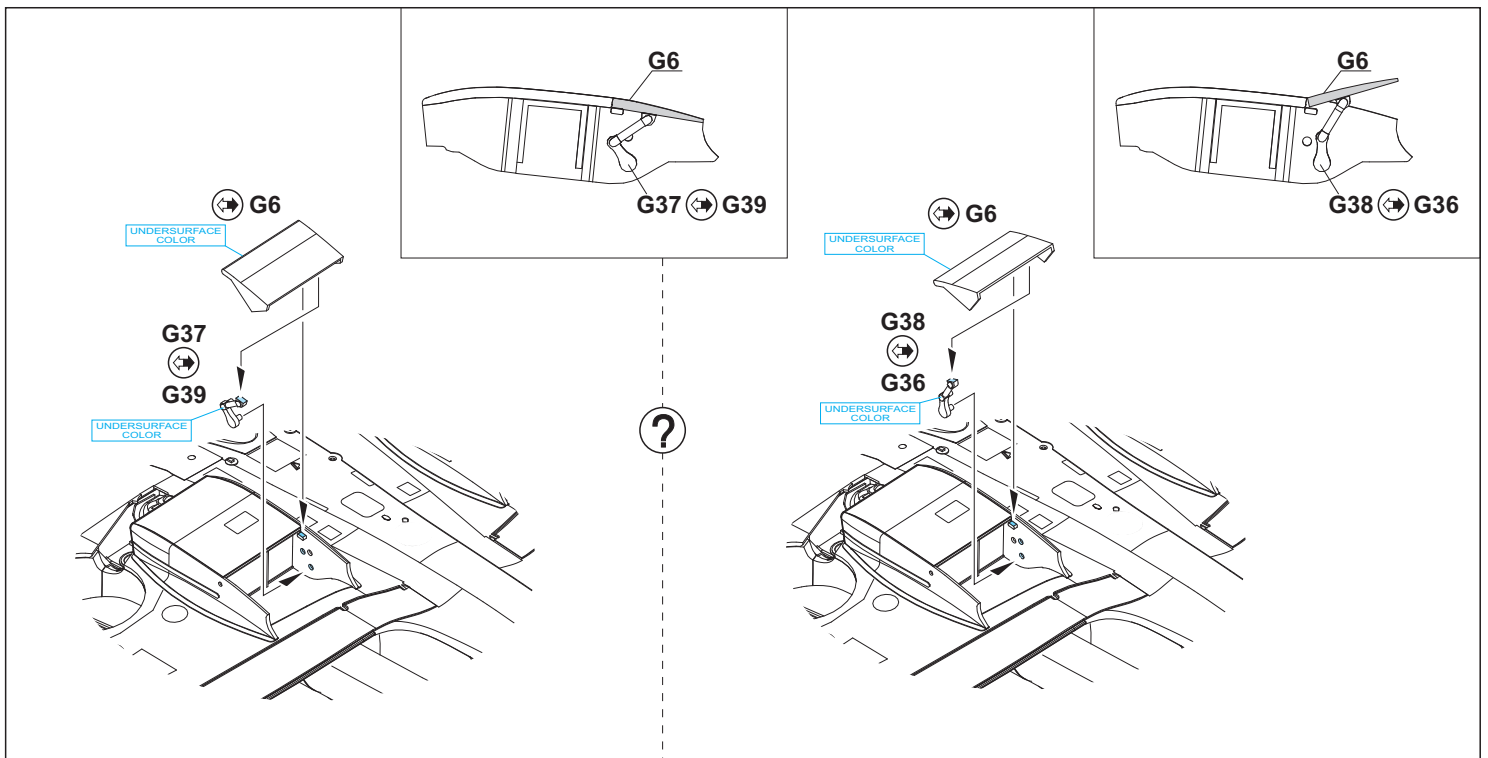

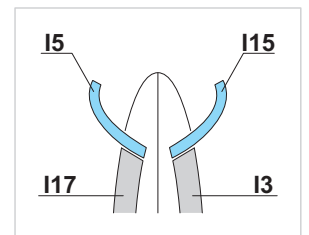
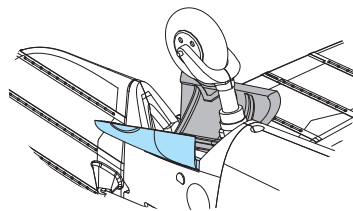
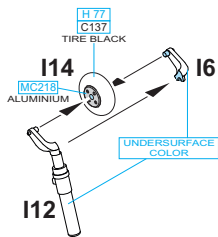
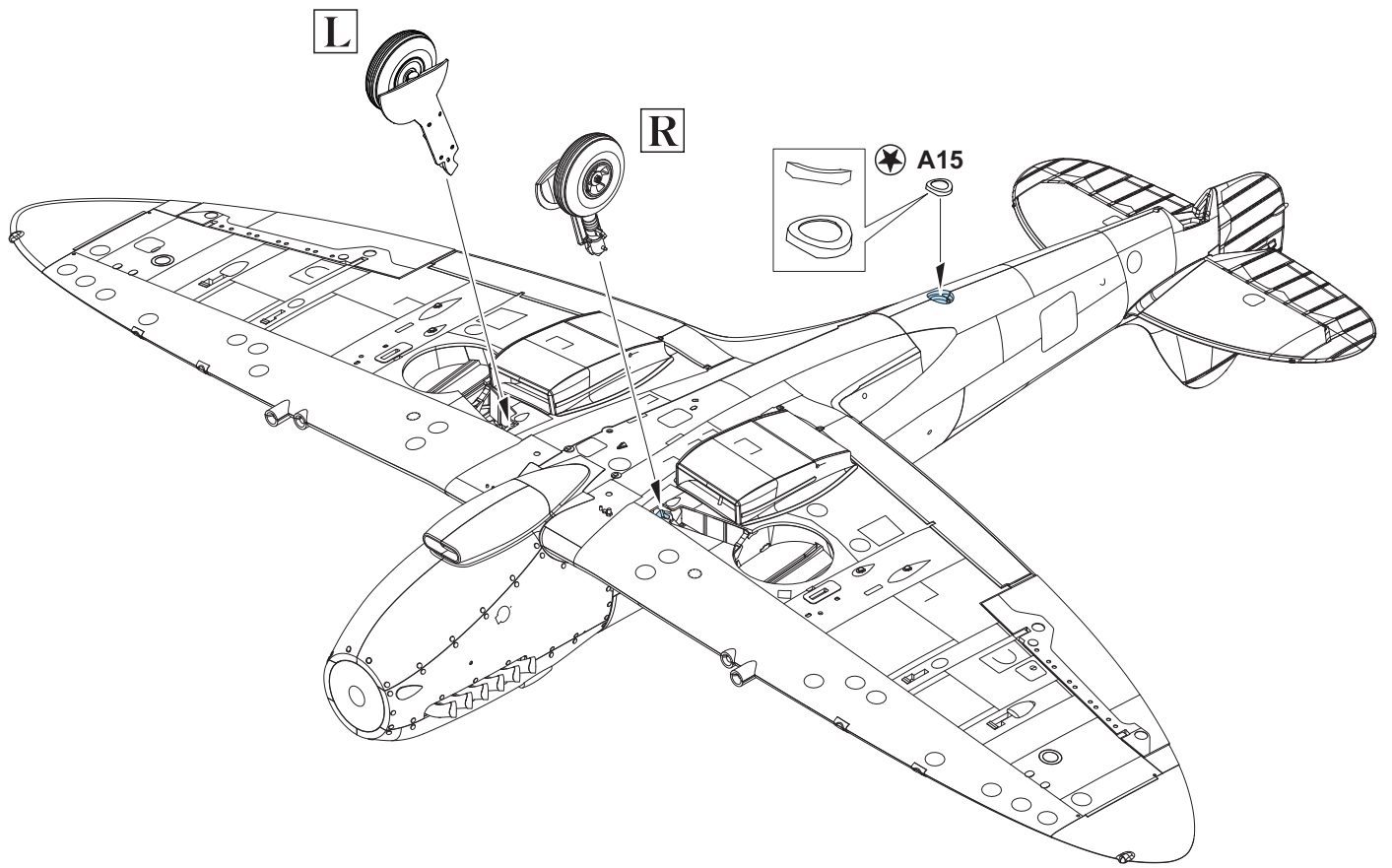

?

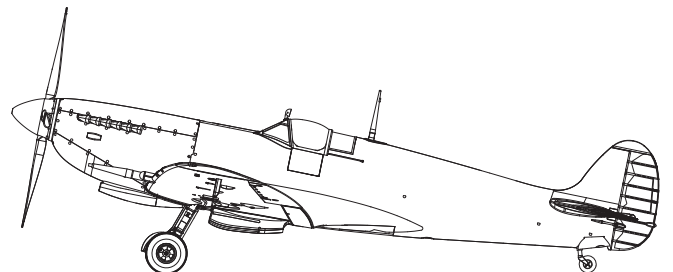
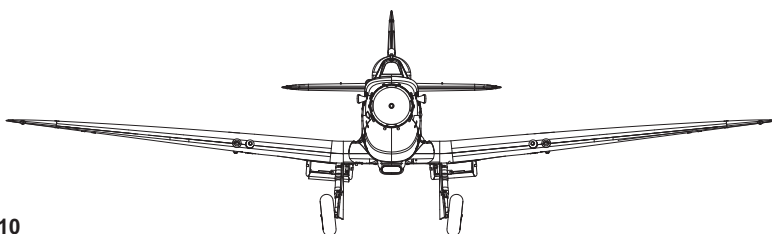
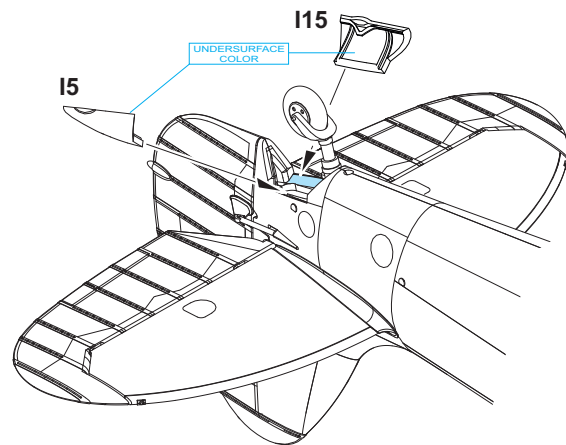
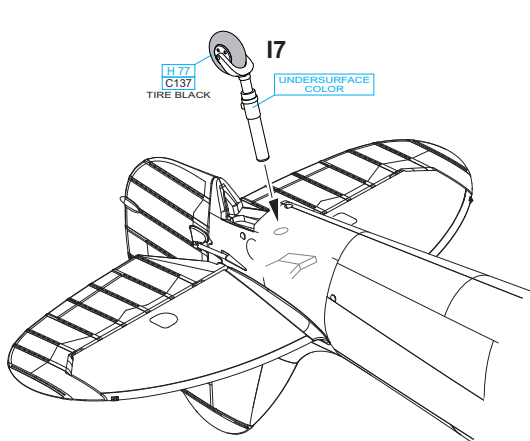

A11 - MARKINGS
A, C, E, F

PE26 - MARKING
D

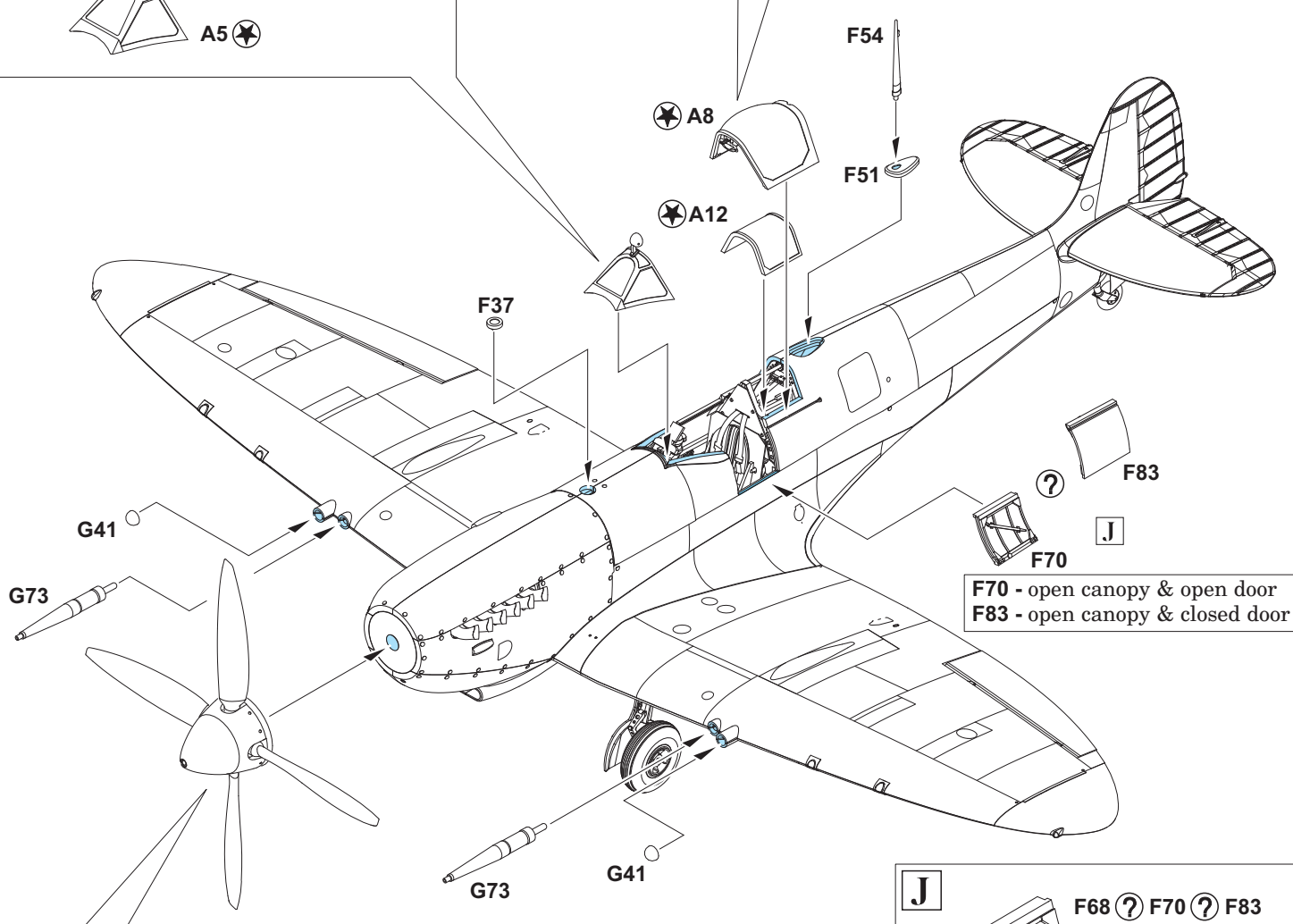
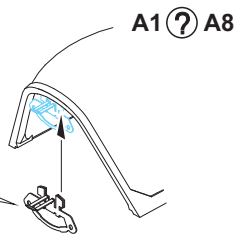
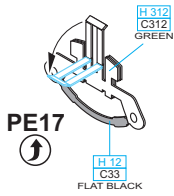
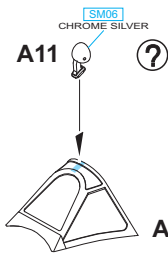

F70 - open canopy & open door
F83 - open canopy & closed door

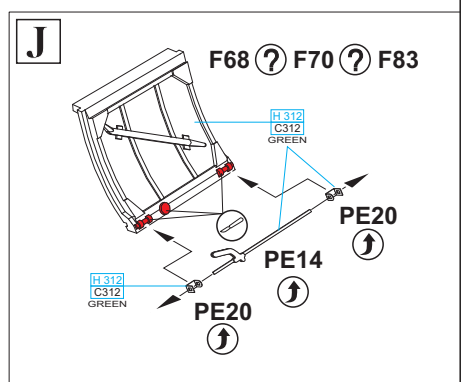

F68 - closed canopy & closed door

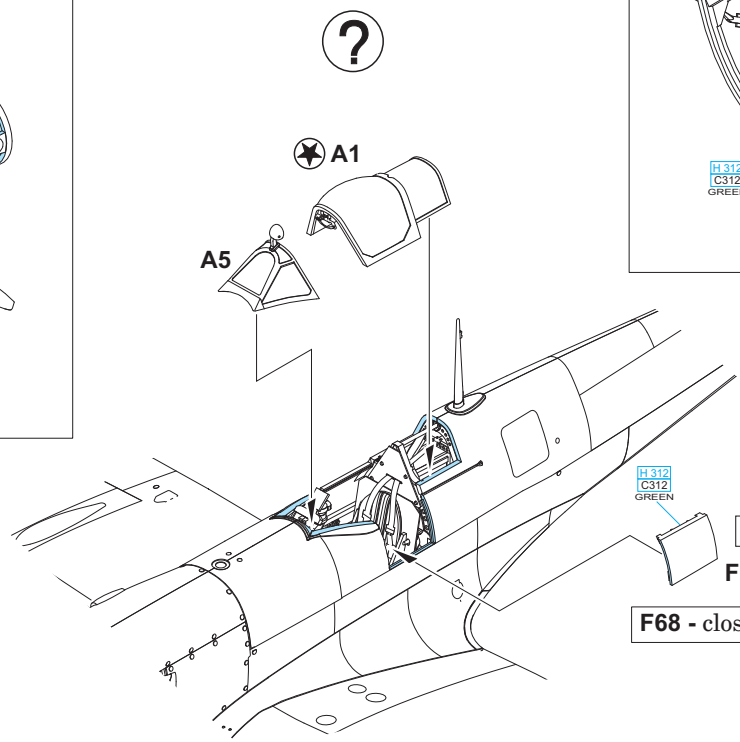
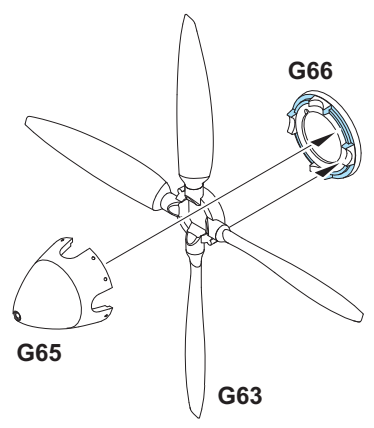

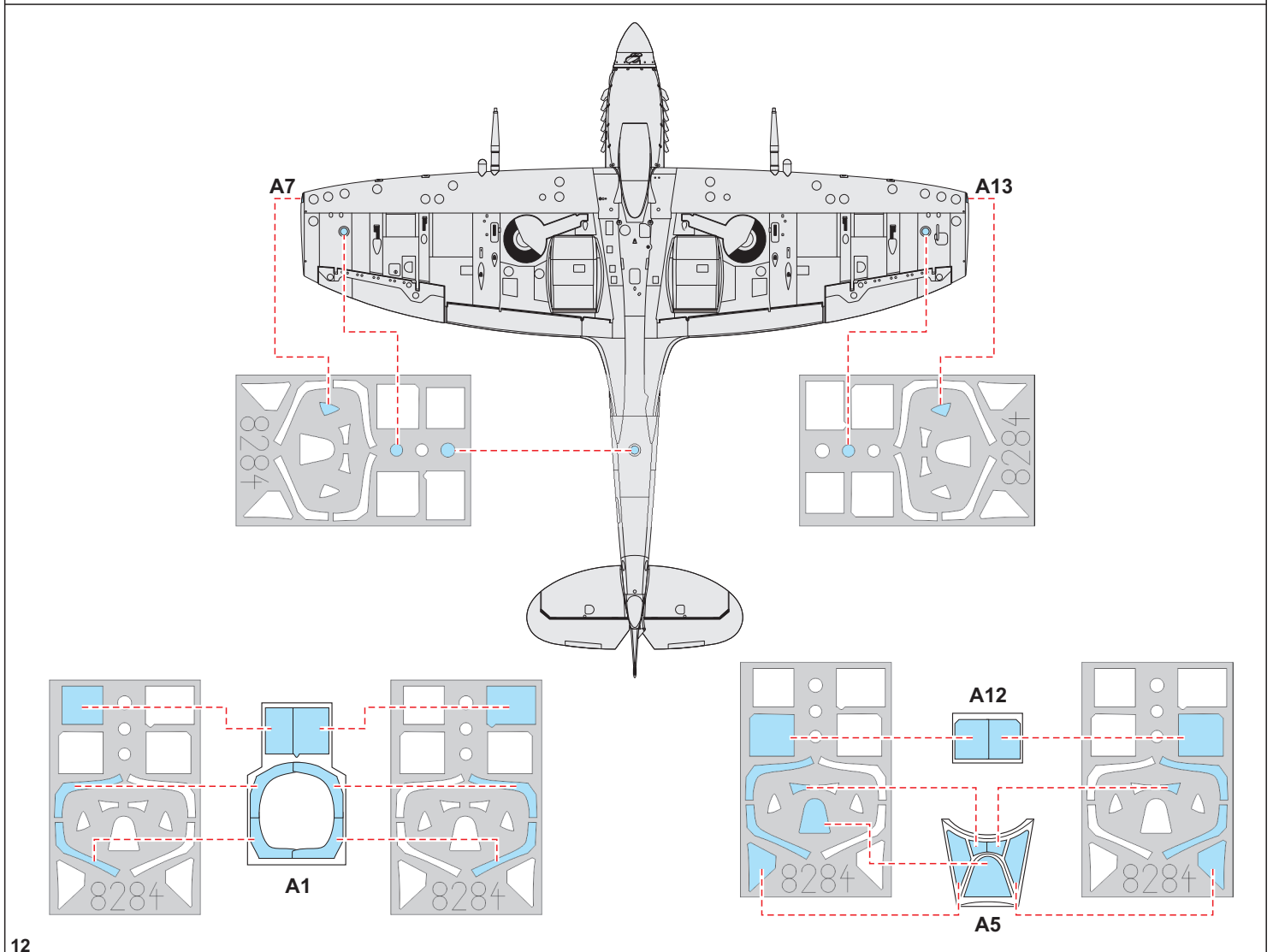
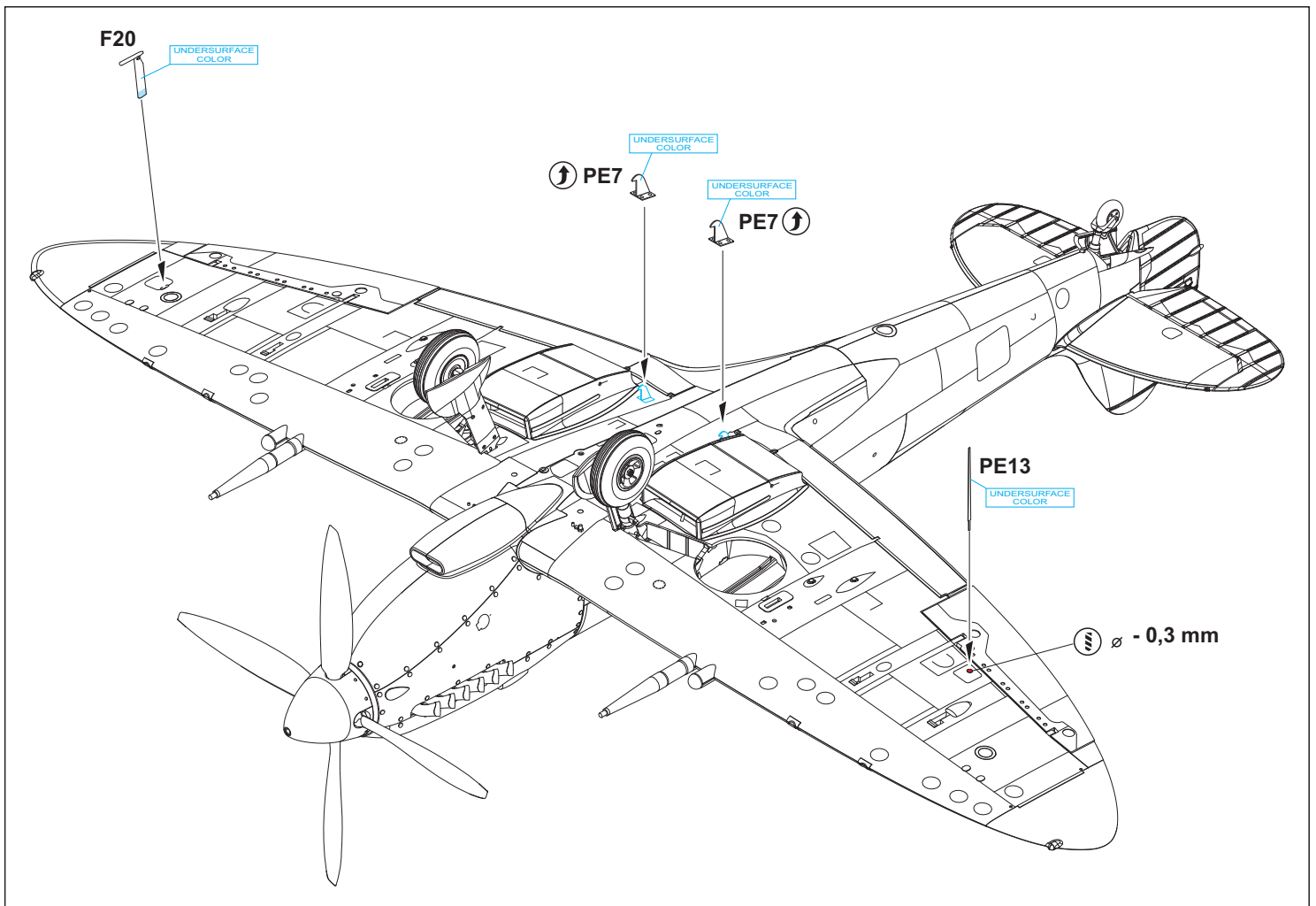

A LF Mk.VIII, MD280, Flown by F/Lt. Paul Ostrander, No. 155 Squadron RAF, Burma, 1945

Paul Ostrander, a Canadian from Winnipeg, joined No. 155 Squadron in India in May, 1944 and flew Spitfire Mk.VIII's from July of the same year and successfully completed his combat tour in May, 1945. Ostrander's Spitfire wore white identification stripes on the wings and tail. It is not clear if a white stripe on the fin is present but this stripe would have been part of the prescribed standard. Both possibilities are possible in this kit. The badge on the nose is based on the Chindits marking – troop units active against the Japanese armed forces in the jungle behind enemy lines.

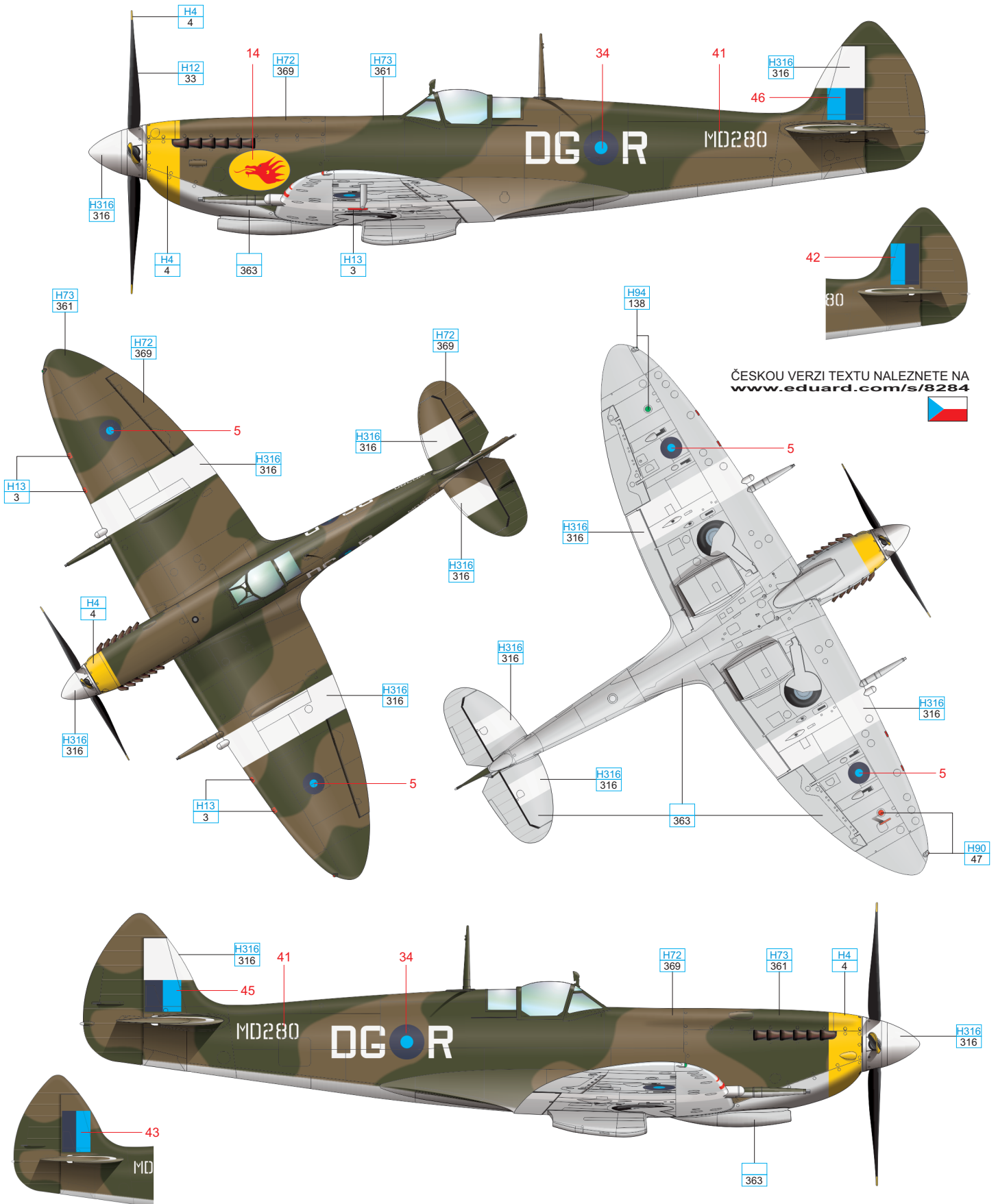

ČESKOU VERZI TEXTU NALEZNETE NA
www.eduard.com/s/8284



YELLOW	H4 4	CLEAR GREEN	H94 138	CLEAR RED	H90 47
---------------	----------------	--------------------	-------------------	------------------	------------------

MEDIUM SEA GRAY	363	DARK EARTH	H72 369	DARK GREEN	H73 361	WHITE	H316 316	BLACK	H12 33
------------------------	------------	-------------------	-------------------	-------------------	-------------------	--------------	--------------------	--------------	------------------

B F Mk.VIII, JF470, 31st Fighter Group, 308th Fighter Squadron, Fano Air Base, Italy, 1944 – 1945

The 31st Fighter Group flew Spitfire Mk.Vs, Mk.VIII and Mk.IXs from June, 1943 till March, 1944. The Group was subsequently re-equipped with P-51 Mustangs but a few Spitfires were retained as hacks. Mustangs flown by this FG had red-yellow stripes on the wing tips. The red color was closer to the wingtips, but it is not clear if the red color position was the same on this Spitfire. The wingtip appears to be yellow in available photos. The camouflage is probably that for high altitude fighters and consists of Medium Sea Grey on upper and PRU blue on lower surfaces. Note the clipped wings.

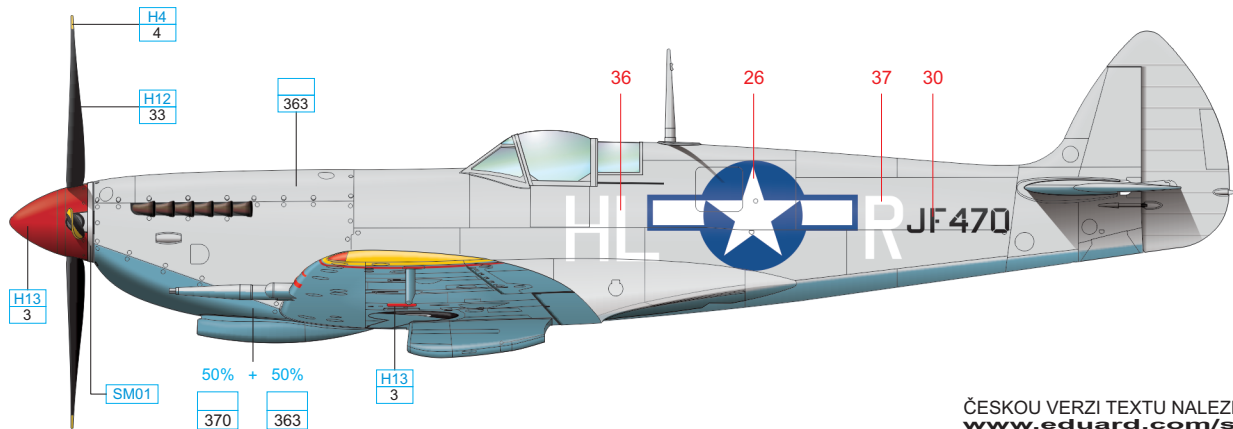

ČESKOU VERZI TEXTU NALEZNETE NA www.eduard.com/s/8284

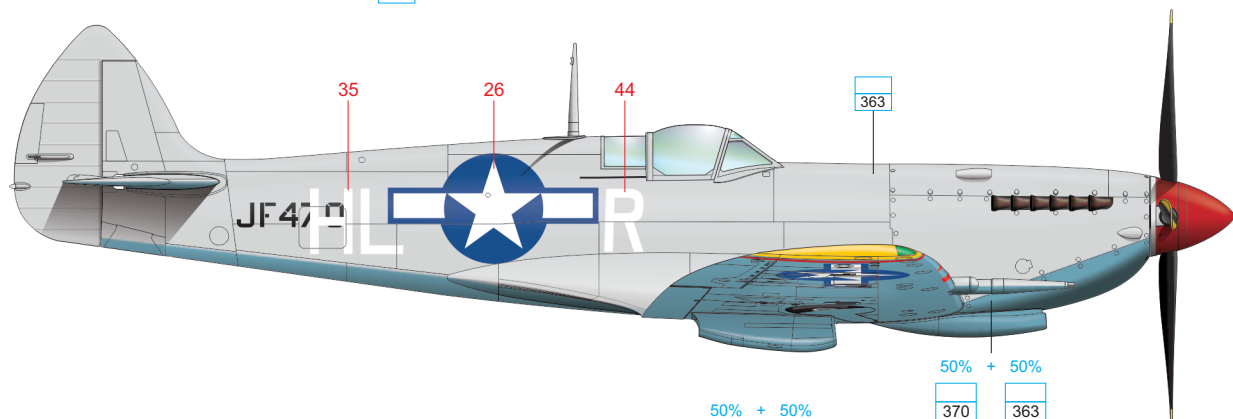
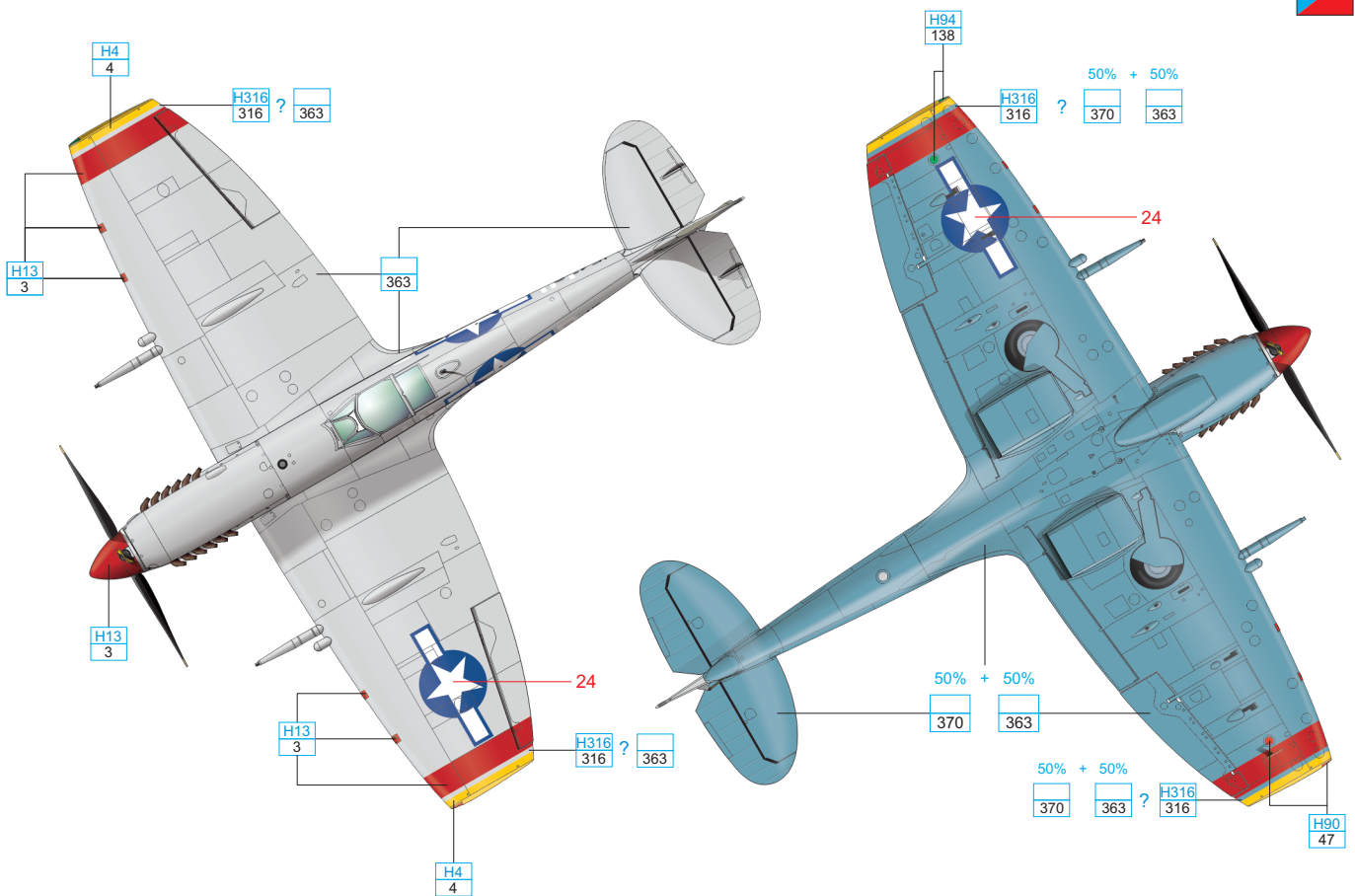

	YELLOW	H4	4		CLEAR GREEN	H94	138		CLEAR RED	H90	47		PRU BLUE	50% + 50%	370	363
	MEDIUM SEA GRAY		363		RED	H13	3		BLACK	H12	33		SILVER	SM01		
									WHITE	H316	316					

C F Mk.VIII, JF330, Flown by AVM Harry Broadhurst, 1943

Harry Broadhurst joined the RAF in 1926. He became an outstanding display pilot and was promoted to CO of various units. He took part in the Battle of Britain and managed to shoot down two Bf 109s on July 2, 1941. Unfortunately, he was downed by AA fire during the same combat sortie. Five days later, Broadhurst's aircraft was damaged yet again, the successful pilot on the German side being pfm. Josef Priller, the JG 26 fighter ace. By August 19, 1942 Broadhurst was credited with 13 confirmed kills, 7 probable kills and 10 damaged enemy aircraft. He was promoted to Air Vice Marshall and took command of the Desert Air Force in January, 1943. As the commanding officer he had the right to use his initials as his aircraft code. The AVM pennant appeared under the windscreen. The aircraft was desert camouflaged and was equipped with extended wingtips.

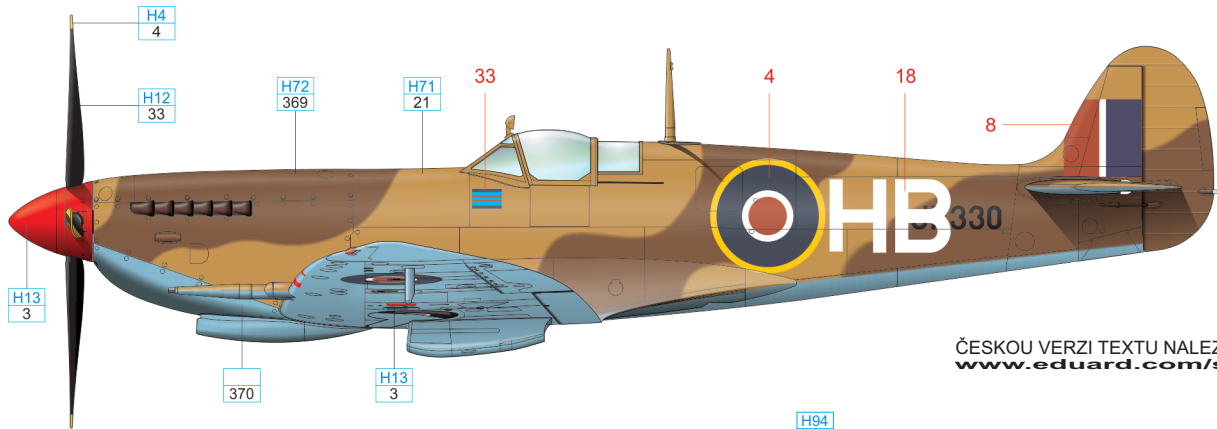

ČESKOU VERZI TEXTU NALEZNETE NA www.eduard.com/s/8284

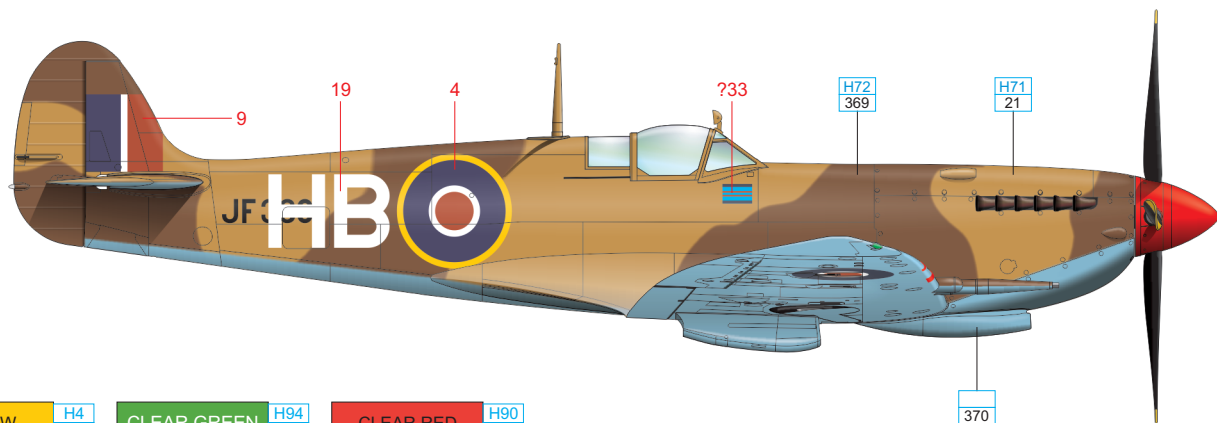
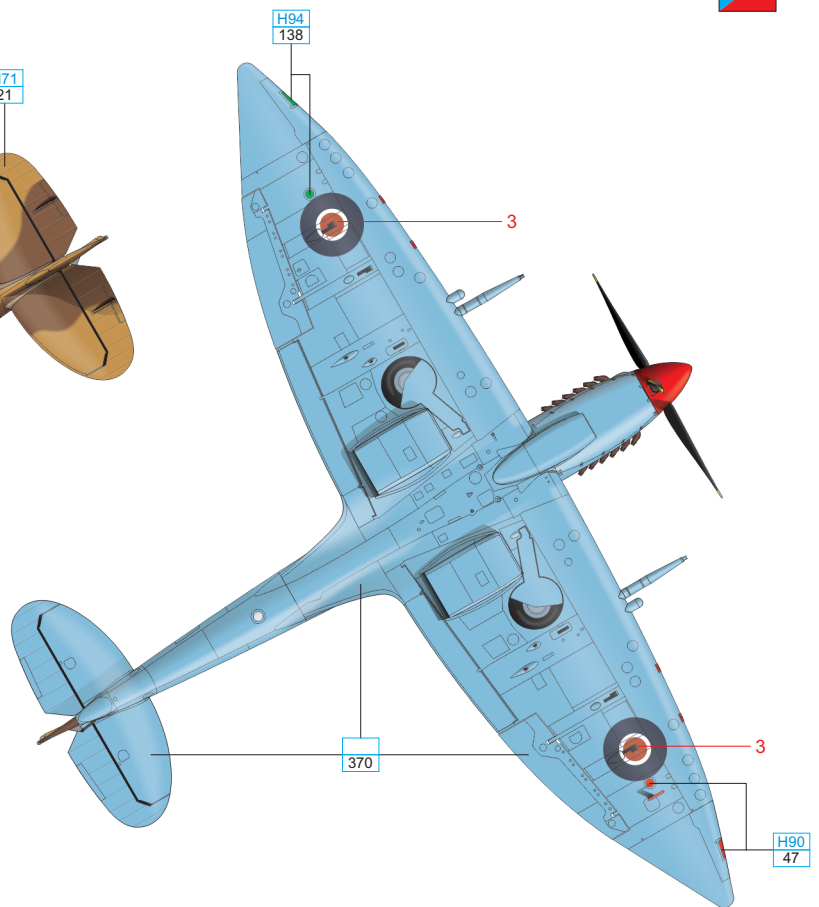
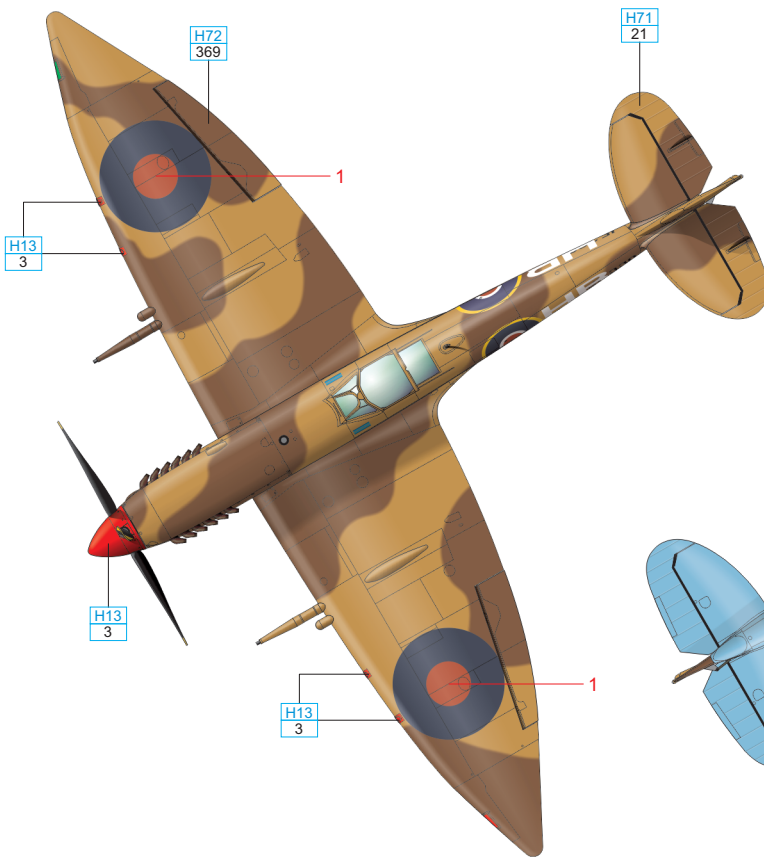

YELLOW	H4 4	CLEAR GREEN	H94 138	CLEAR RED	H90 47
AZURE BLUE	370	DARK EARTH	H72 369	MIDDLE STONE	H71 21
				RED	H13 3
				BLACK	H12 33

D F Mk.VIII, JF404, No. 32 Squadron RAF, Foggia Air Base, Italy, Early 1944

The high altitude fighter camouflage scheme adorned this Spitfire as well. In accordance with regulations, red-blue cockades were painted on the fuselage and upper sides of the wings. No national insignia was applied on the bottom of the wings. A photo of this aircraft shows that the GZ code letters did not adhere to regulations on the right side of the fuselage. The aircraft was equipped with extended wingtips.

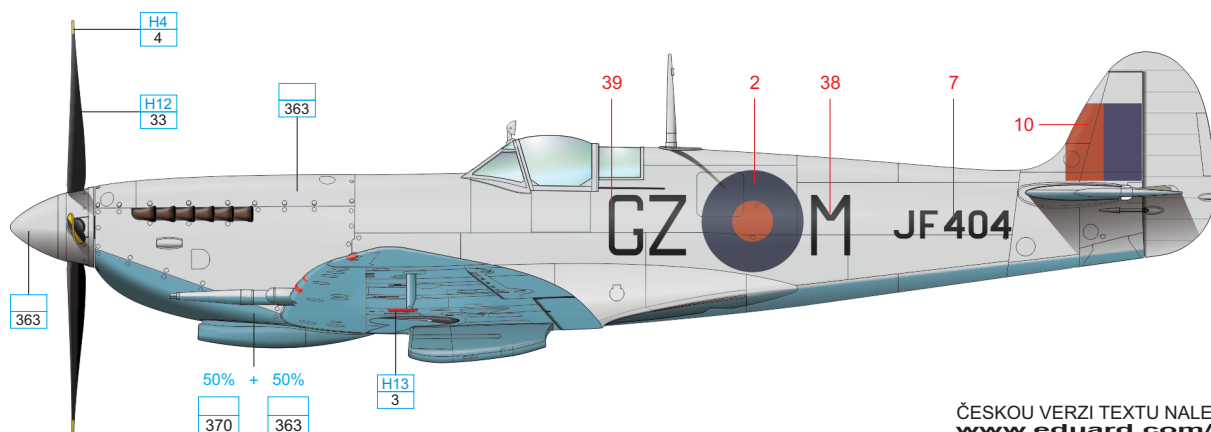

ČESKOU VERZI TEXTU NALEZNETE NA www.eduard.com/s/8284

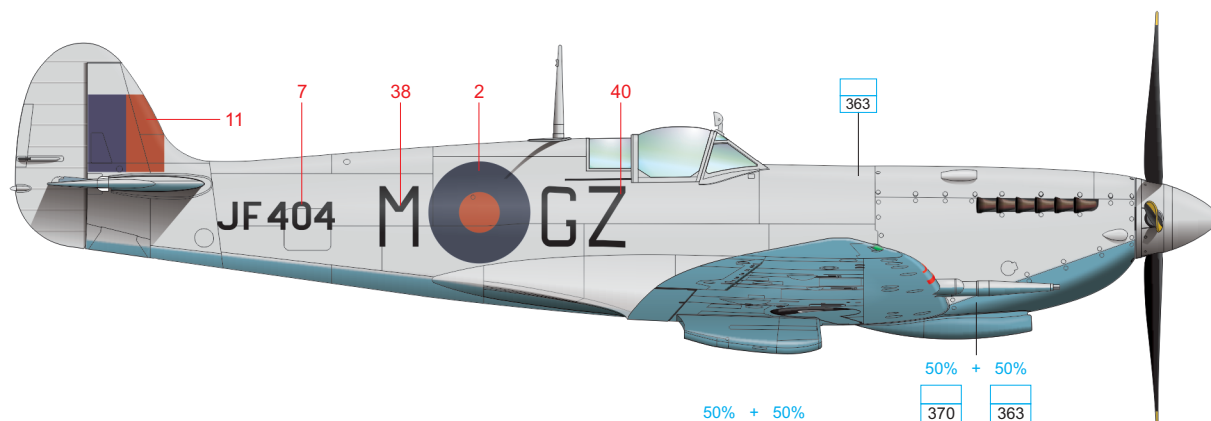
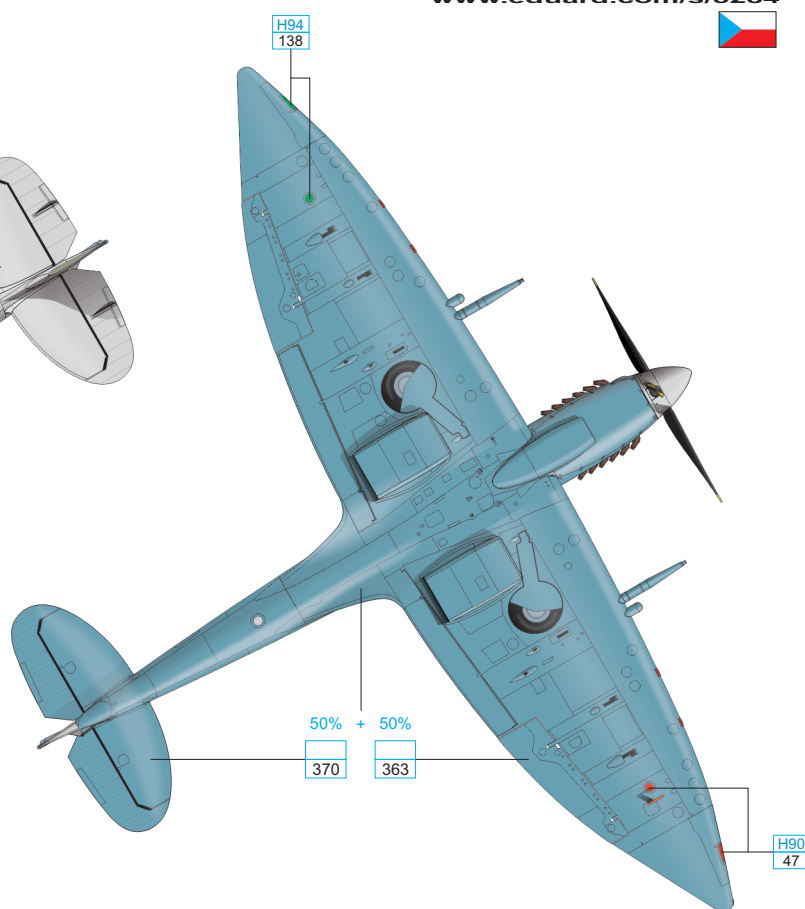
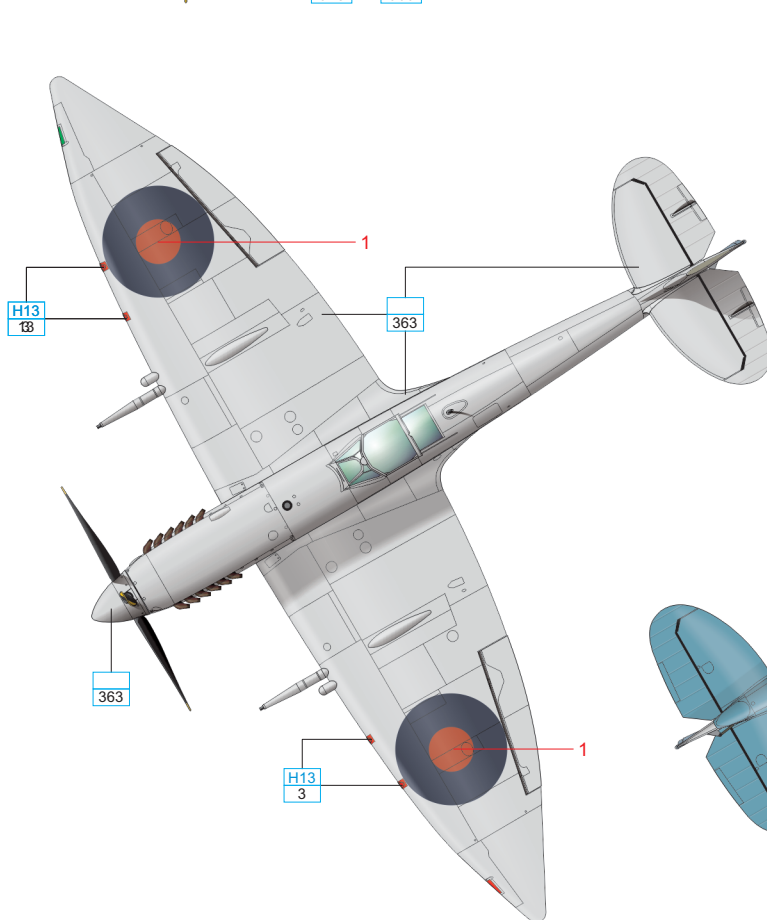

YELLOW	H4 4	CLEAR GREEN	H94 138	CLEAR RED	H90 47	PRU BLUE	50% + 50% 370 363
MEDIUM SEA GRAY	363	RED	H13 3	BLACK	H12 33		

E LF Mk.VIII, MT714, Flown by F/Lt A. W. Guest, No. 43 Squadron RAF, Ramatuelle Air Field, France, August, 1944

Fifteen Spitfire Mk.VIII's were delivered to No. 43 Squadron, RAF, in July, 1944. Squadron pilots flew them till October of the same year from Calvi Air Field, Sardinia, and from various bases located in Southern France. This Spitfire wore the day fighter camouflage scheme. It was accepted by the RAF in June, 1944 and assigned to No. 43 Squadron on July 13, 1944. MT714 was written off on March 14, 1946.

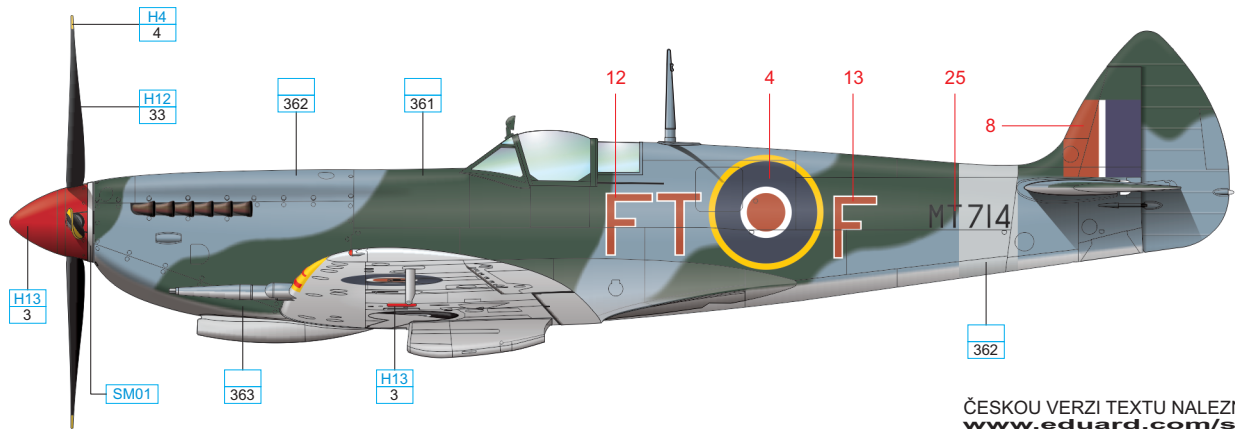

ČESKOU VERZI TEXTU NALEZNETE NA www.eduard.com/s/8284

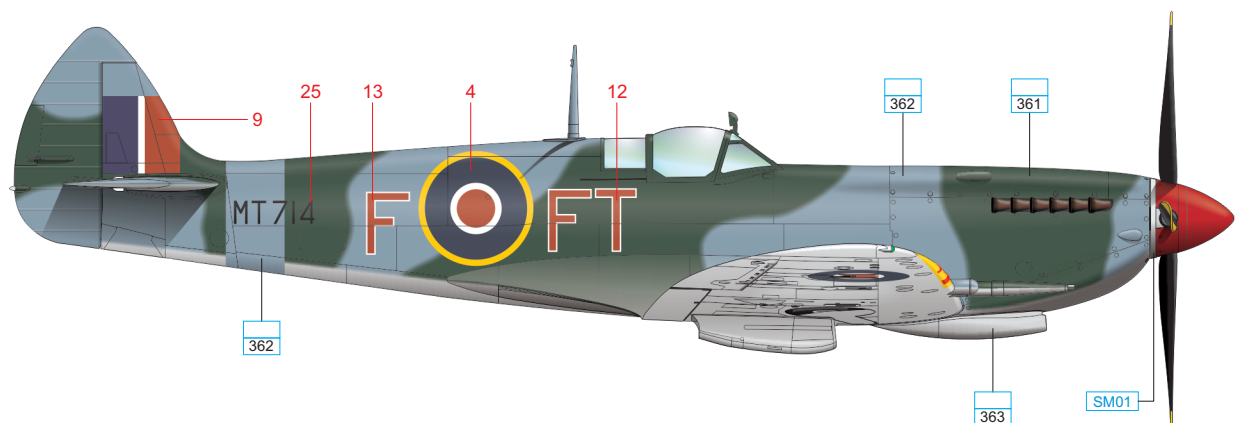
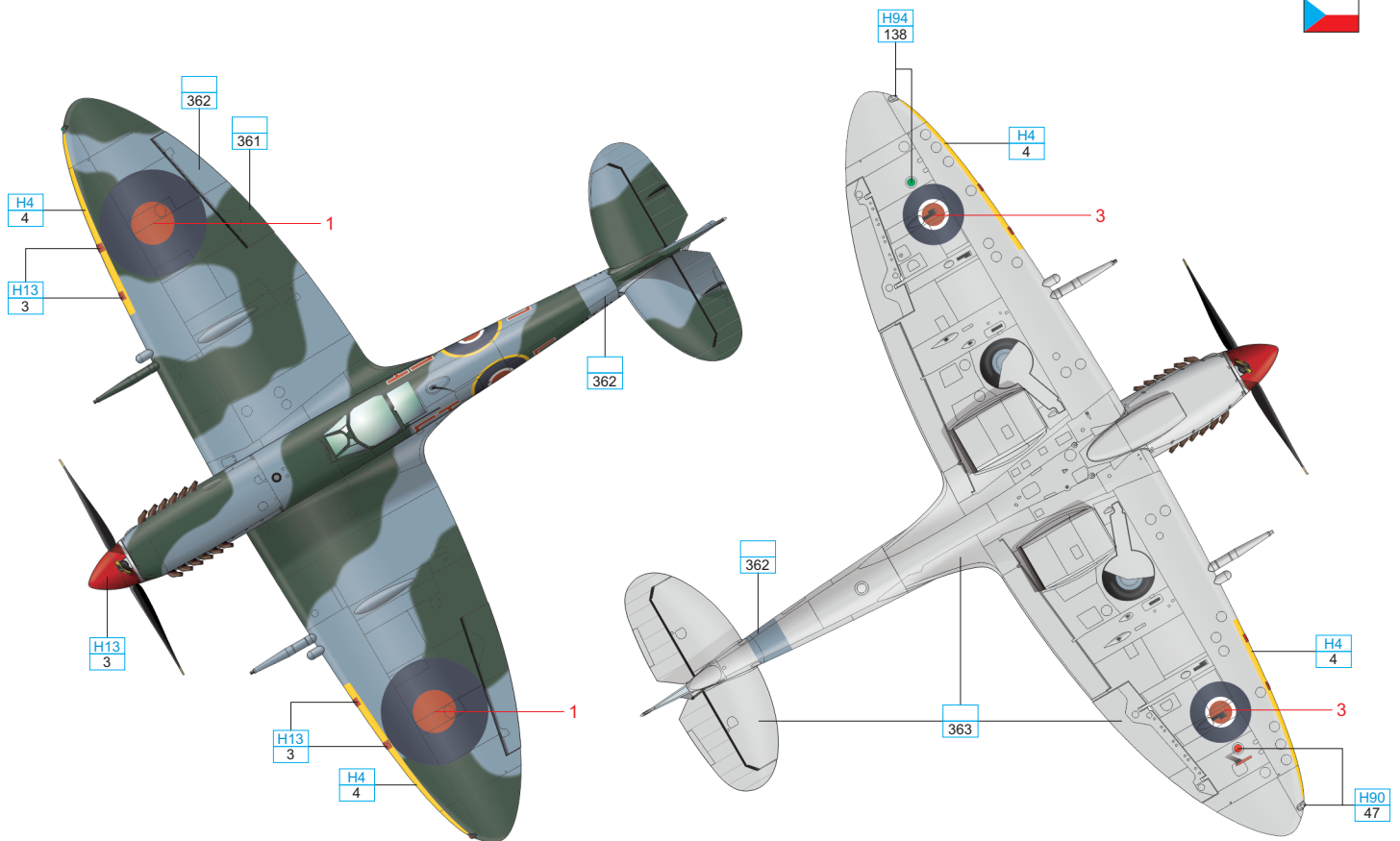

YELLOW	H4 4	CLEAR GREEN	H94 138	CLEAR RED	H90 47	SILVER	SM01
MEDIUM SEA GRAY	363	OCEAN GRAY	362	DARK GREEN	361	RED	H13 3
						BLACK	H12 33

F HF Mk.VIII, Flown by W/C Robert Gibbes, CO of No. 80 Fighter Wing, Dutch East Indies, 1945

The Spitfire Mk.VIII flown by W/C Bobby Gibbes, a fighter ace credited with 12 kills (2 shared), carried the marking of No. 457 Squadron, RAAF. The kill marks under the canopy are inclusive of Gibbes' score from the Mediterranean Theatre of Operations. He served with No. 3 Squadron RAAF at that time. The quick identification marking composed of white leading edges of the wings, appeared on Australian Spitfires in mid 1943 for the first time and No.80 Fighter Wing subsequently adopted them. At least two versions of the sharkmouth were painted on this Spitfire, and we offer up the earlier style. Note the up-side down oriented ace of spades on the rudder.

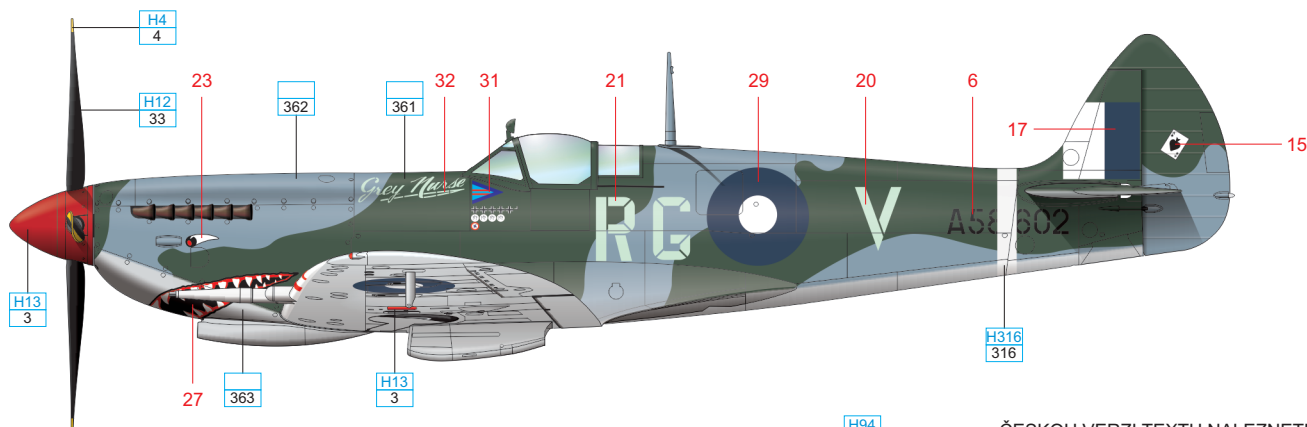

ČESKOU VERZI TEXTU NALEZNETE NA www.eduard.com/s/8284

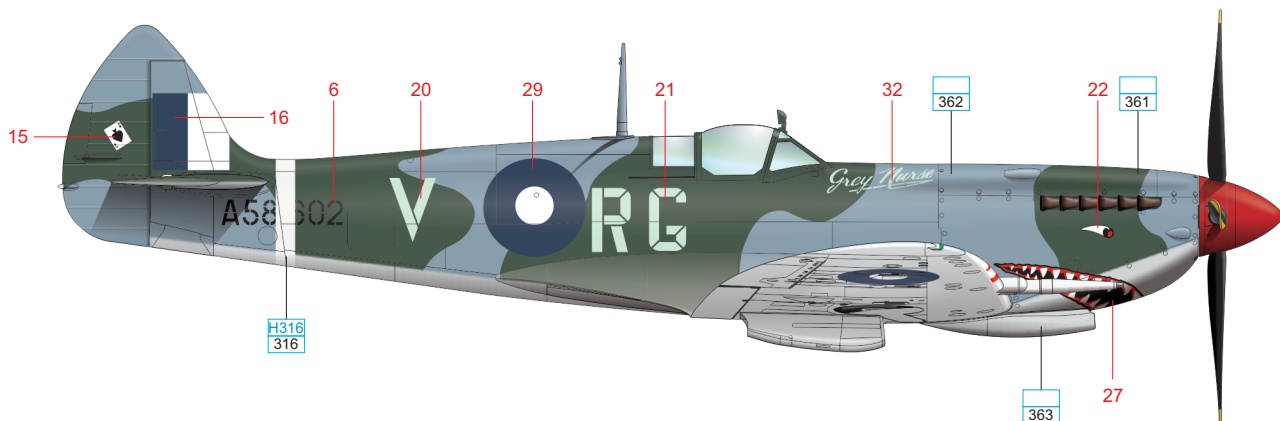
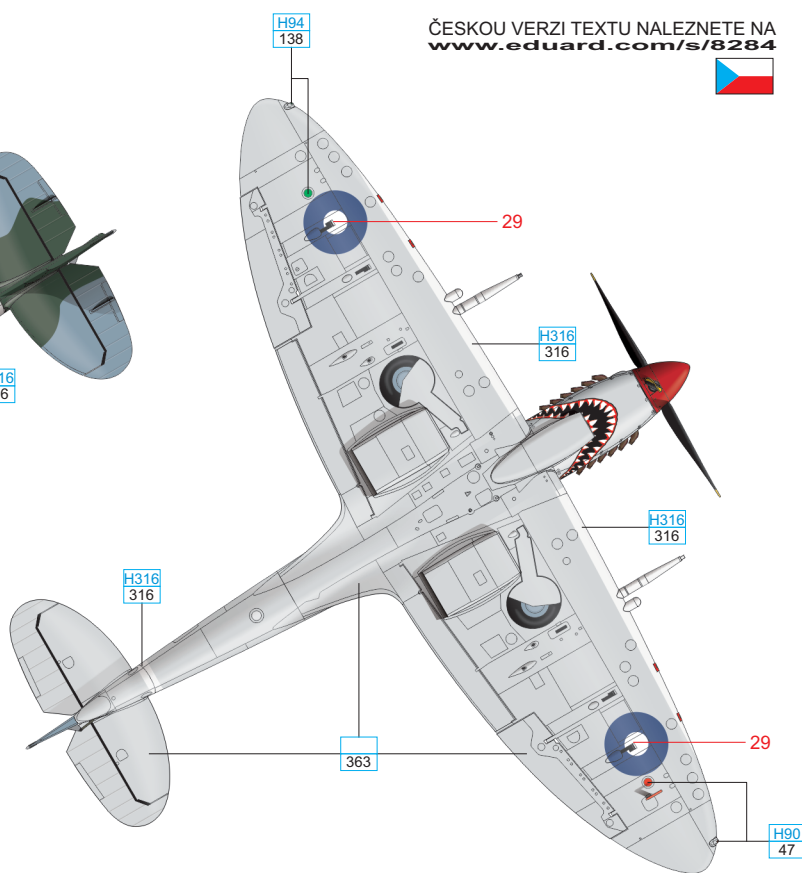
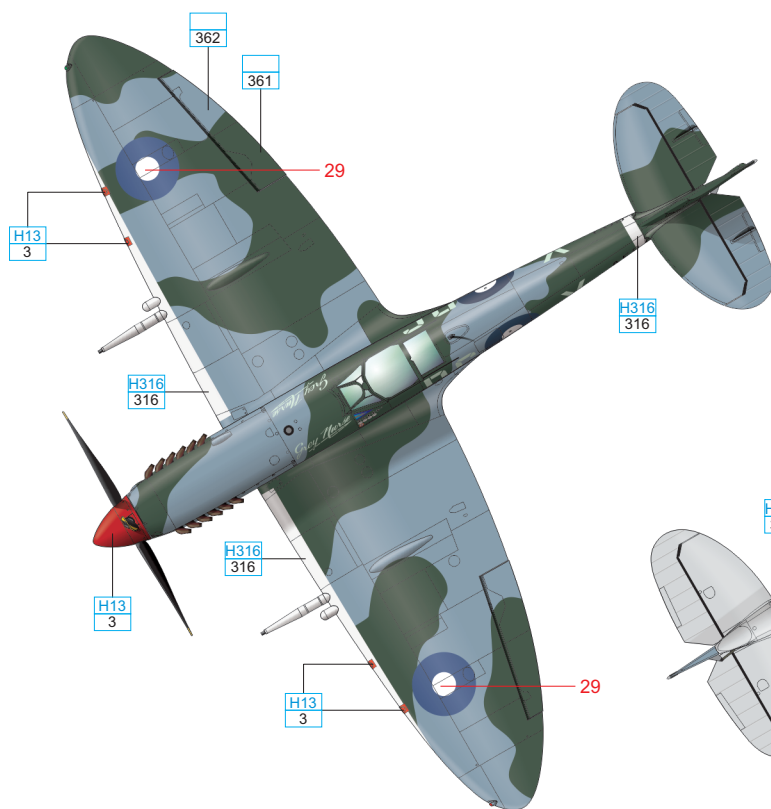

YELLOW	H4 4	CLEAR GREEN	H94 138	CLEAR RED	H90 47	WHITE	H316 316
MEDIUM SEA GRAY	363	OCEAN GRAY	362	DARK GREEN	361	RED	H13 3
						BLACK	H12 33



Spitfire Mk.VIII

1/48 **goodies**

eduard

Brassin and photo-etched accessories

Spitfire Mk.VIII engine

Cat. No. 648200

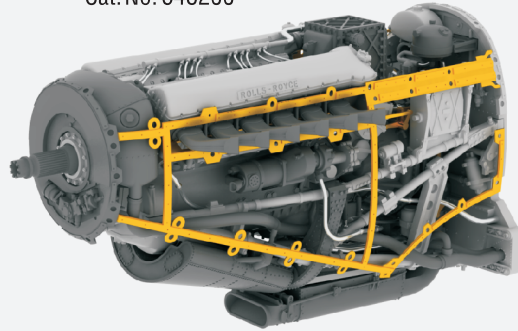

Spitfire Mk.VIII cockpit

Cat. No. 648199



Spitfire wheels - 4 spoke

Cat. No. 648115



Spitfire wheels - 4 spoke w/pattern

Cat. No. 648118

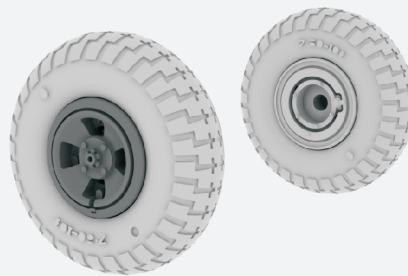

Spitfire exhaust stacks fishtail

Cat. No. 648099

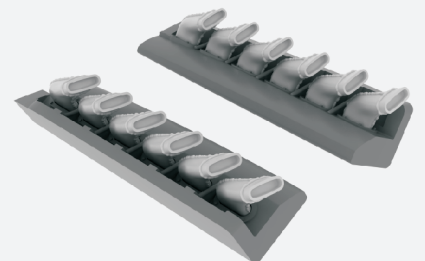

Spitfire Mk.VIII gun bays

Cat. No. 648201

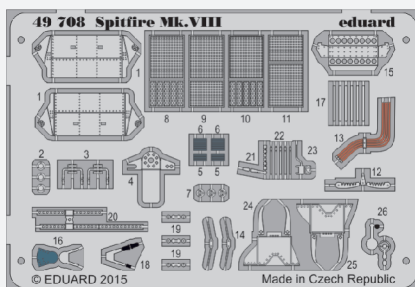
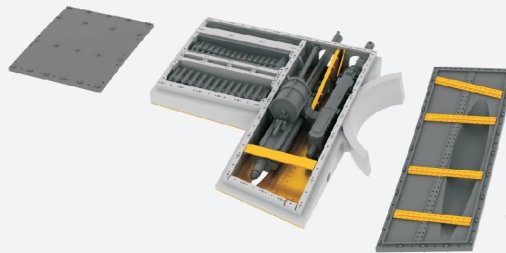

PHOTO-ETCHED SETS

Landing flaps, surface panels and exterior

