

## US SUPERSONIC FIGHTER 1:48 SCALE PLASTIC KIT



### intro

The development of the F-104 Starfighter was launched by the Lockheed company at the very beginning of the 50s, inspired by Korean War experience. The prototype of the new aircraft made its maiden flight on February 17, 1956. The USAF accepted the F-104 in 1958 and flew it till 1969. Starfighters fought in the Vietnam War as well. USAF service was followed up by service within National Guard units .

NATO countries flew Starfighters of various versions. The F-104A was in USAF service from 1958 through to 1960, and then flown by ANG until 1963 when they were recalled by the USAF Air Defense Command for the 319th and 331st Fighter Interceptor Squadrons. Some were purchased by Jordanian, Pakistani, and Taiwanese armed forces.

The next single-seater version was the F-104C fighter-bomber, operated by the USAF Tactical Air Command. Only 77 examples were built.

1,122 examples of the F-104G, an improved version of the C model, were produced as multi-role fighter-bombers. Manufactured by Lockheed, and under license by Canadair and the Consortium that consists of European companies; Messerschmitt/MBB, Dornier, Fiat, Fokker and SABCA. This version typically had a strengthened fuselage, wing structure, and strengthened landing gear with larger tires, increased internal fuel capacity, an enlarged vertical fin, revised flaps for improved combat maneuvering and upgraded avionics.

The TF-104G was a combat-capable trainer version with no cannon and centerline pylon. Internal fuel capacity was also reduced. A total of 220 aircraft of this type were built.

The F-104S interceptor was mainly produced by FIAT and Aeritalia. It had upgraded avionics, radar, two additional wing and two underbelly hardpoints, upgraded J79-GE-19 engine with afterburner, and two additional ventral fins for increased stability during high-speed flight. F-104Gs flew many hours in the service of not only the five NATO countries depicted in this kit, but also in the service of other NATO countries such as Denmark, Greece, U.S.A. and later, Spain.

### úvodem

Vývoj letounu F-104 Starfighter začal u společnosti Lockheed na samém počátku 50. let na základě zkušeností z korejské války. Prototyp poprvé vzlétl 17. února 1956. Do stavu USAF se dostal v roce 1958 a létal zde až do roku 1969, zapojil se i do války ve Vietnamu. Na tuto službu navázalo působení u Národní gardy.

Členské státy NATO používaly postupem času řadu verzí Starfighteru. USAF sloužily v řadách USAF v letech 1958 až 1960, poté je až do roku 1963 využívaly jednotky Národní gardy. Následně našly uplatnění u USAF Air Defence Command. Nakonec byly uvolněny k prodeji, čehož využily Jordánsko, Pakistán a Taiwan.

Další jednomístnou verzí byl stíhací bombardér F-104C. Vzniklo celkem 77 kusů, které sloužily u USAF Tactical Air Command.

Další modernizace F-104C vedla ke vzniku F-104G, s 1122 postavenými exempláři nejpočetnější verzi Starfighteru. Vyráběl ji jak Lockheed, tak na základě licenčního ujednání Canadair, a konsorcium evropských firem složené ze společností Messerschmitt/MBB, Dornier, Fiat, Fokker a SABCA. Modernizace zahrnovala zesílení trupu, křídla, podvozku, jenž byl osazen koly s většími pneumatikami. Zvětšena byla kapacita palivových nádrží, zvětšena plocha kýlové plochy, přepracované vztlačkové klapky přispěly k lepší obratnosti a vylepšena byla avionika.

TF-104G byla dvojměstná verze bez palubního kanonu a podtrupového pylonu. Nesla méně paliva. Postaveno bylo celkem 220 kusů.

Přepadová verze F-104S opouštěla zejména výrobní linky společností FIAT a Aeritalia. Opět dostala modernizovanou avioniku, radar, čtyři body pro montáž závěsníků, motor J79-GE-19 s přídatným spalováním a dvě dodatečné kýlové plošky, které zlepšovaly stabilitu letounu při vysokých rychlostech.

Kromě států zastoupených v této stavebnici sloužily F-104G také v dalších zemích, které byly či se posléze staly členy NATO – v Dánsku, Řecku, U.S.A a ve Španělsku.

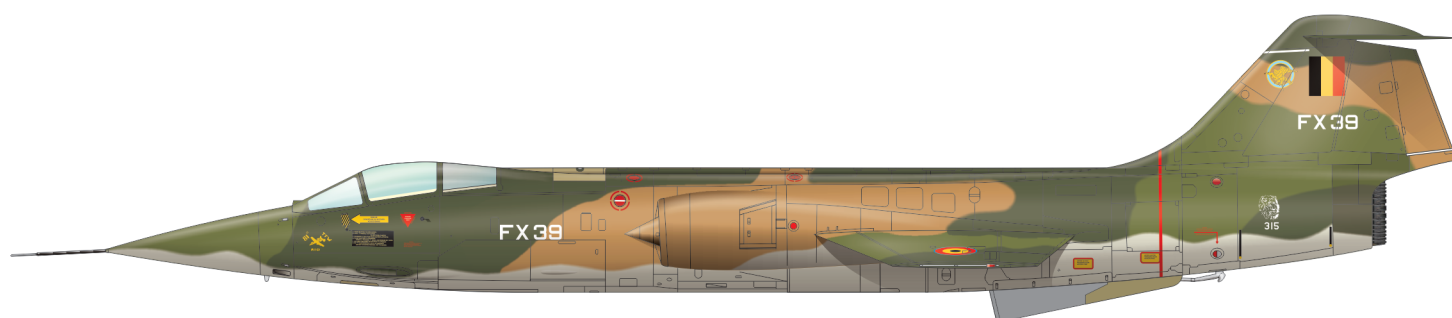



Carefully read instruction sheet before assembling. When you use glue or paint, do not use near open flame and use in well ventilated room. Keep out of reach of small children. Children must not be allowed to suck any part, or pull vinyl bag over the head.



Před započítím stavby si pečlivě prostudujte stavební návod. Při používání barev a lepidel pracujte v dobře větrané místnosti. Lepidla ani barvy nepoužívejte v blízkosti otevřeného ohně. Model není určen malým dětem, mohlo by dojít k požití drobných dílů.

## INSTRUCTION SIGNS \* INSTR. SYMBOLS \* INSTRUKTION SINNBILDEN \* SYMBOLES \* 記号の説明



OPTIONAL  
VOLBA



BEND  
OHNOUT



OPEN HOLE  
VYVRTAT OTVOR



SYMMETRICAL ASSEMBLY  
SYMETRICKÁ MONTÁŽ



REMOVE  
ODŘÍZNOUT



REVERSE SIDE  
OTOČIT



APPLY EDUARD MASK  
AND PAINT  
POUŽÍT EDUARD MASK  
NABARVIT

## PARTS



## DÍLY



## TEILE



## PIÈCES



## 部品

## PLASTIC PARTS

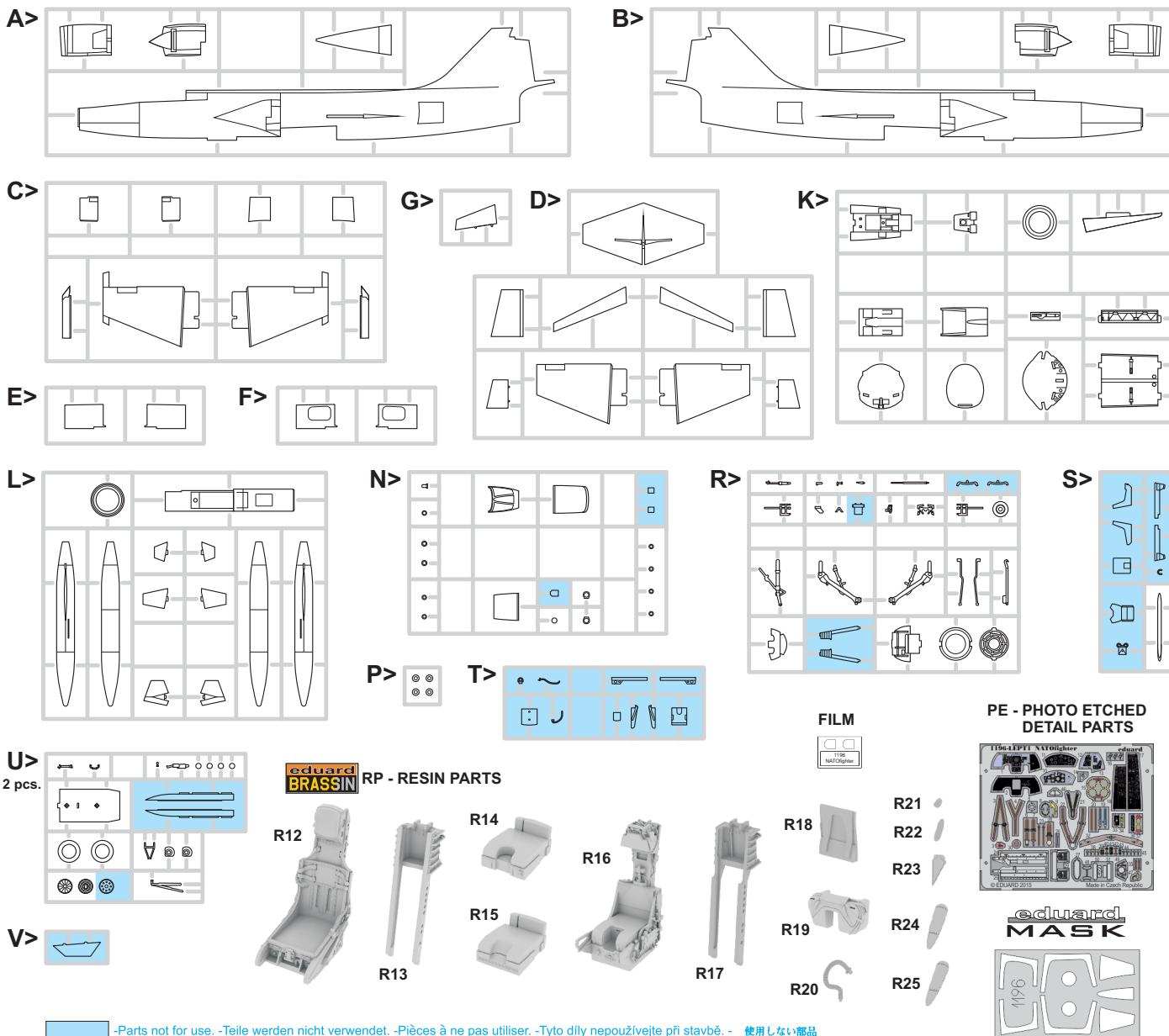

## COLOURS



## BARVY



## FARBEN



## PEINTURE



## 色

GSI Creos (GUNZE)		
AQUEOUS	Mr.COLOR	
H 3	C3	RED
H 8	C8	SILVER
H 12	C33	FLAT BLACK
H 14	C59	ORANGE
H 27	C44	TAN
H 52	C12	OLIVE DRAB
H 53	C13	NEUTRAL GRAY
H 64	C17	DARK GREEN
H 77	C137	TIRE BLACK

AQUEOUS	Mr.COLOR	
H 80	C54	KHAKI GREEN
H 90	C47	CLEAR RED
H 94	C138	CLEAR GREEN
H 307	C307	GRAY
H 303	C303	GREEN
H 305	C305	GRAY
H 308	C308	GRAY
H 309	C309	GREEN
H 310	C310	BROWN

AQUEOUS	Mr.COLOR	
H 311	C311	GRAY
H 316	C316	WHITE
H 317	C317	GRAY
H 338	C338	LIGHT GRAY
Mr.METAL COLOR		
MC213		STAINLESS
MC214		DARK IRON
Mr.COLOR SUPER METALLIC		
SM01		SUPER FINE SILVER

**A**

OPTIONAL:  
decal 68  
PE18

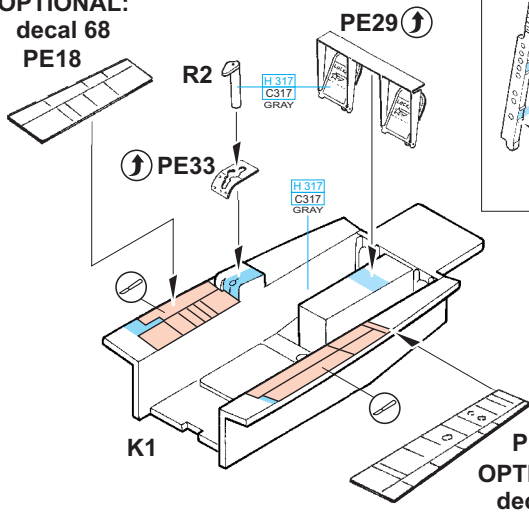

MARKING B ONLY

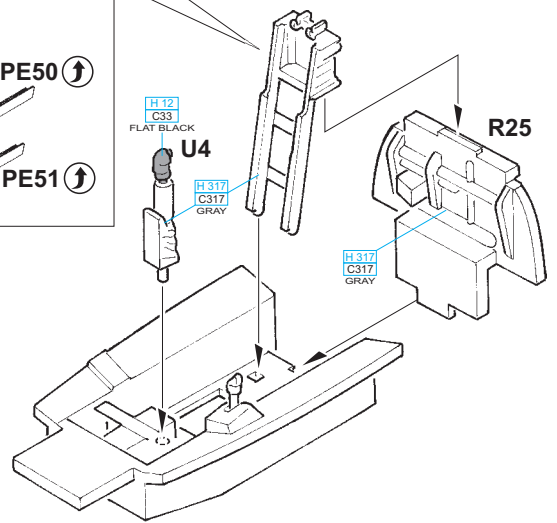
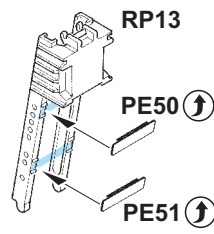
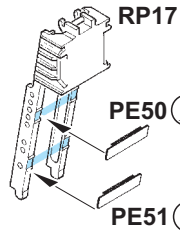
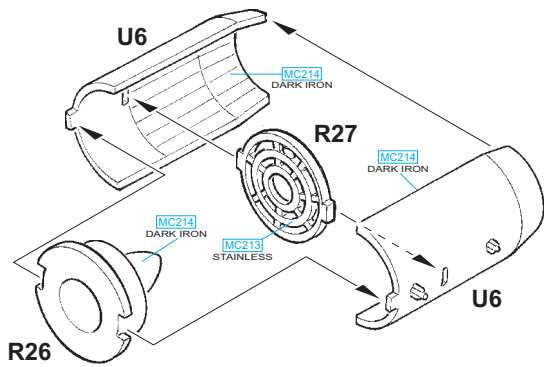
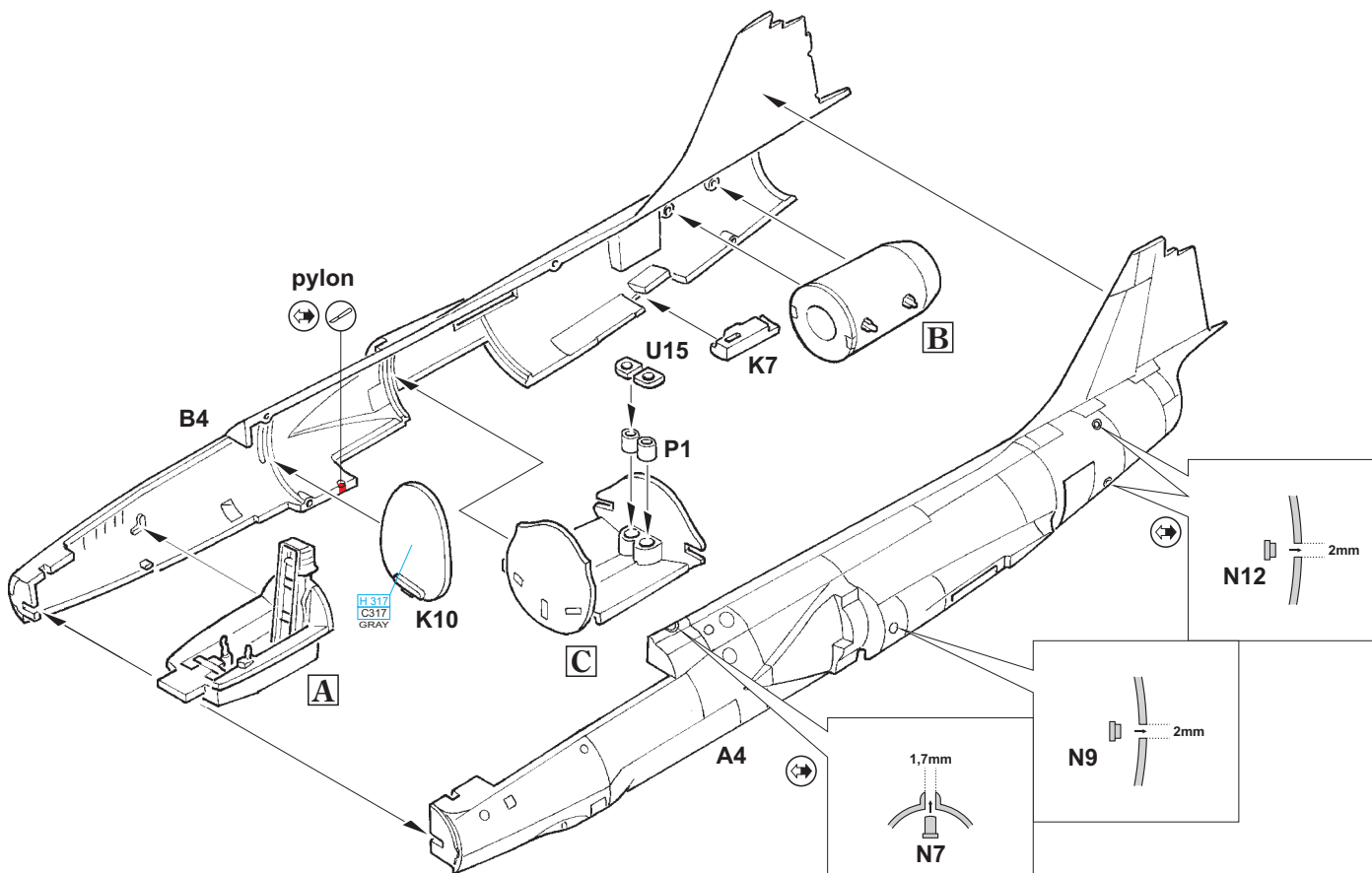
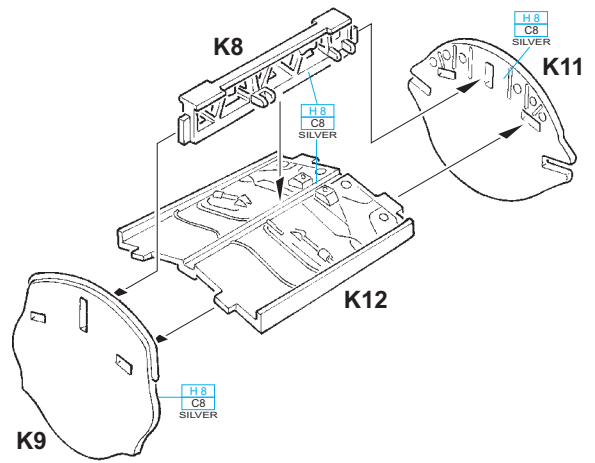
**B****C**

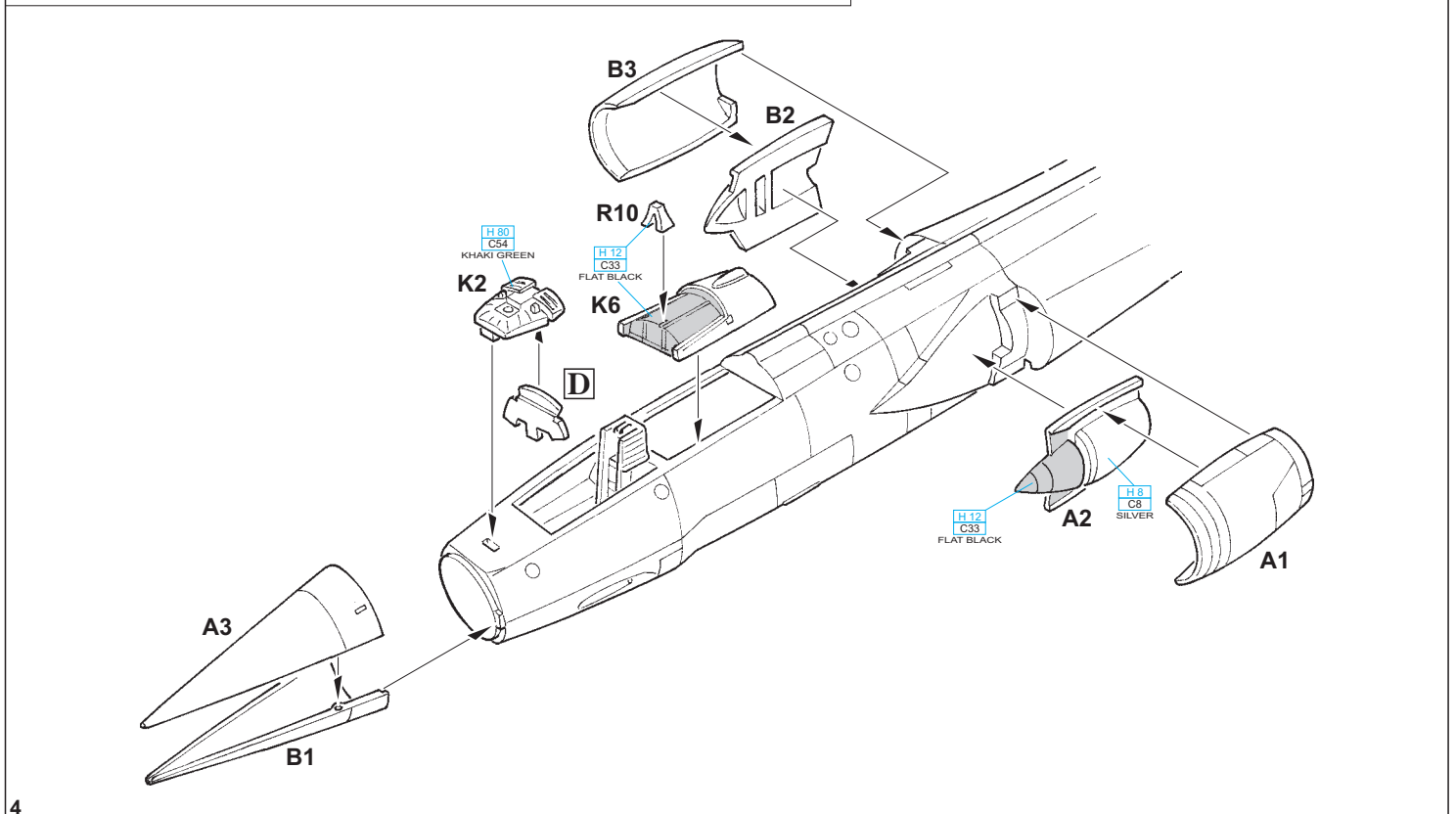
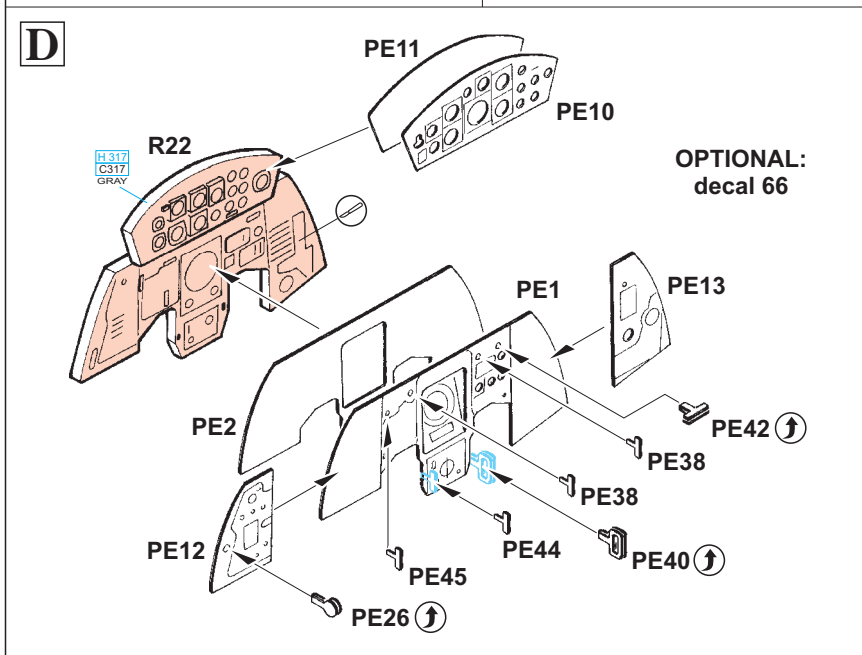
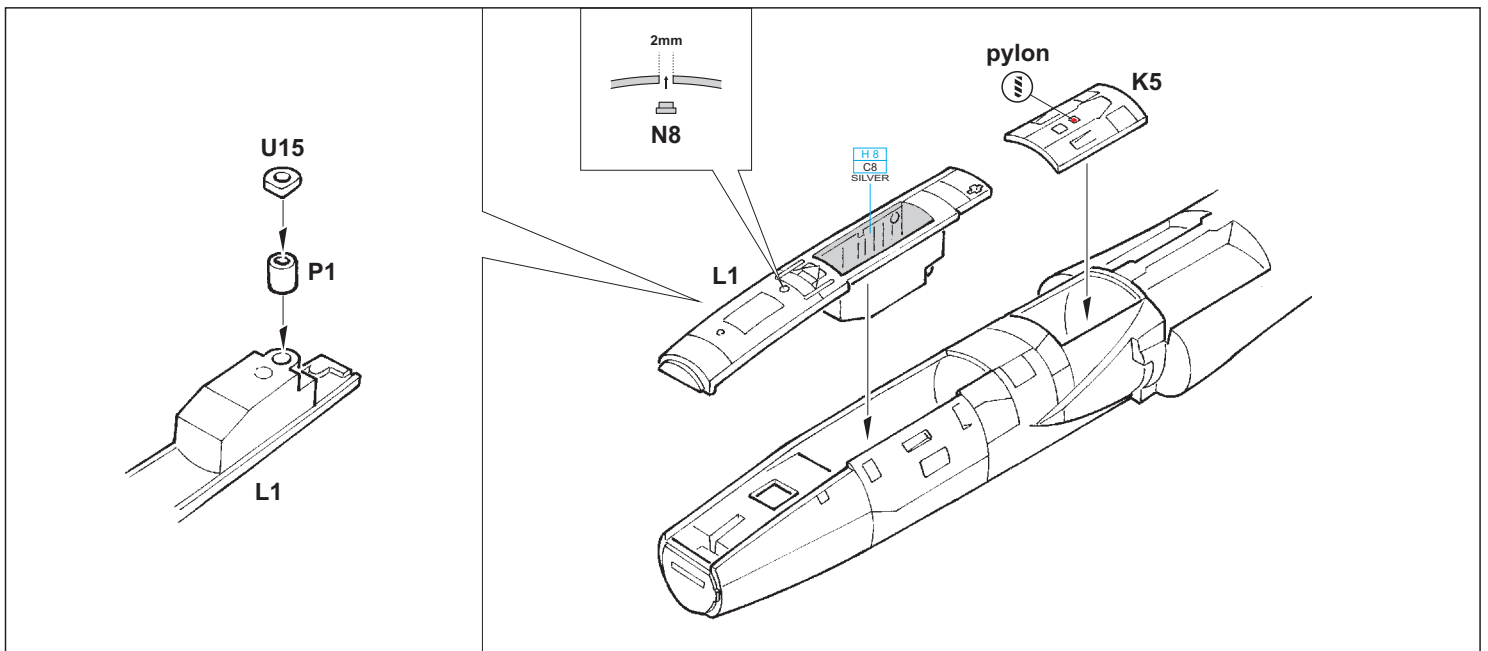

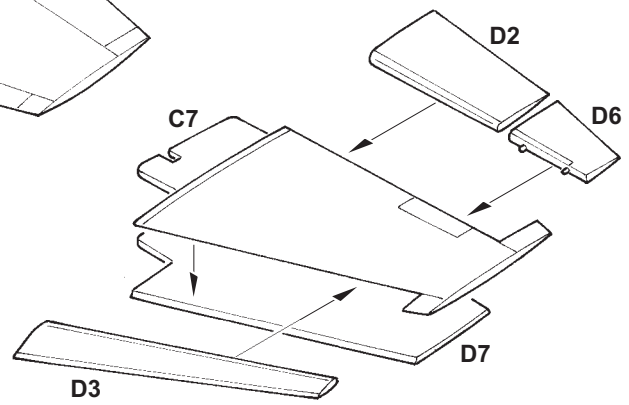
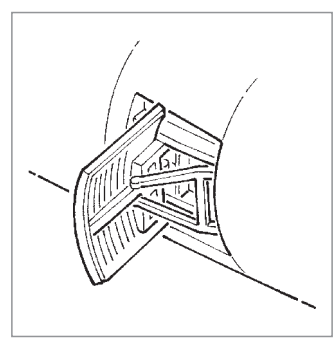
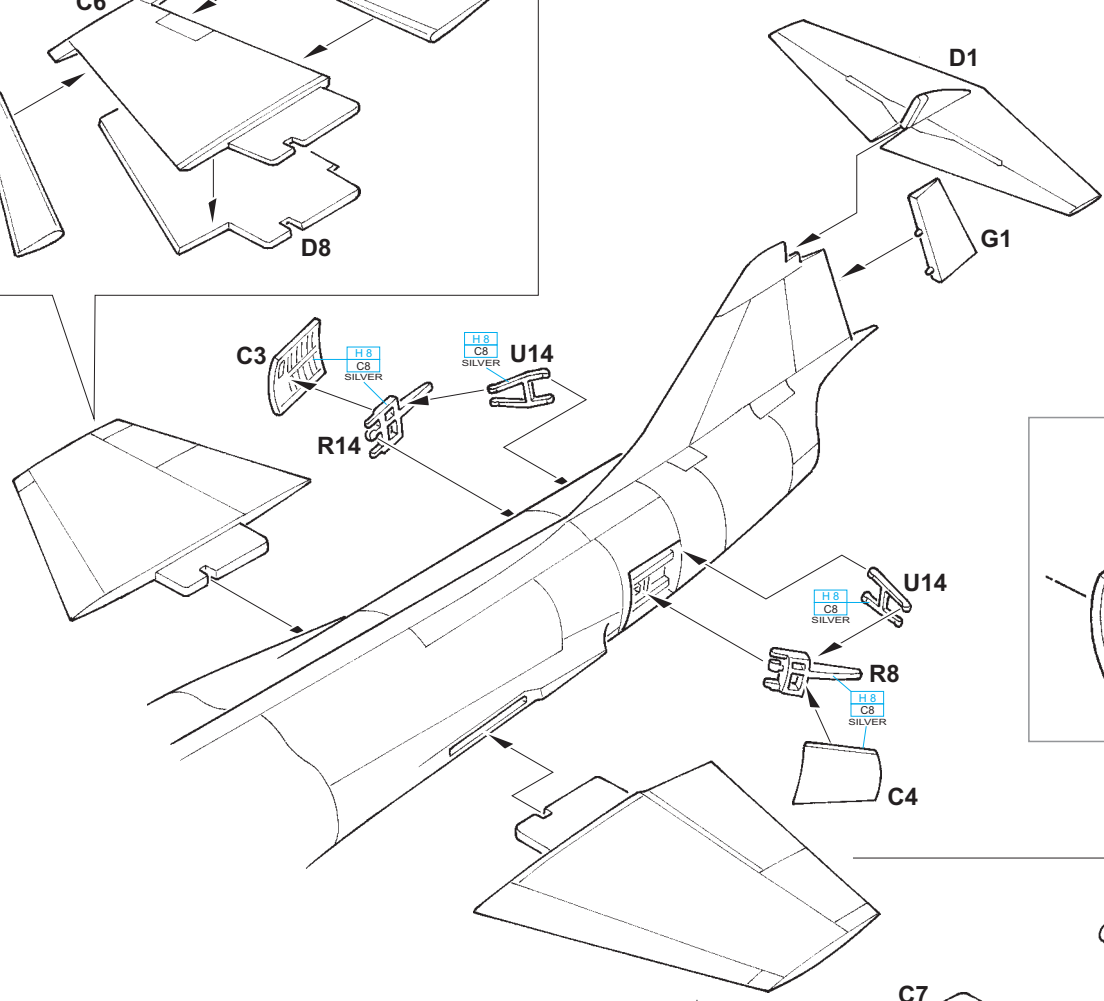
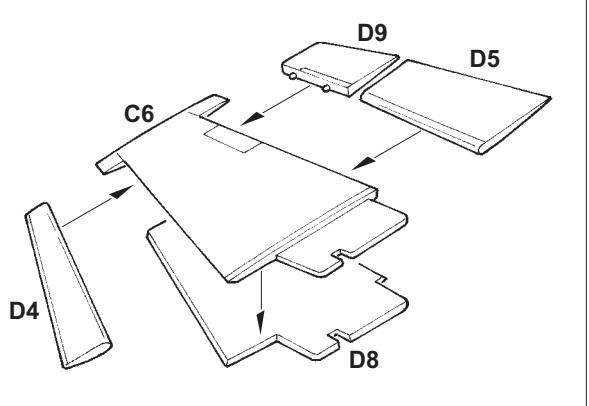
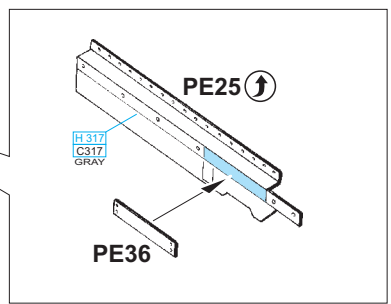
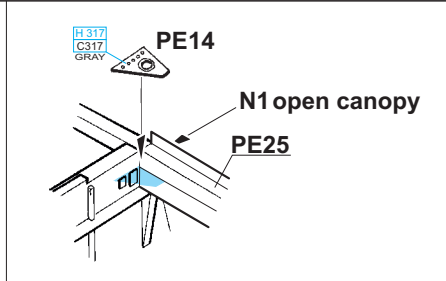
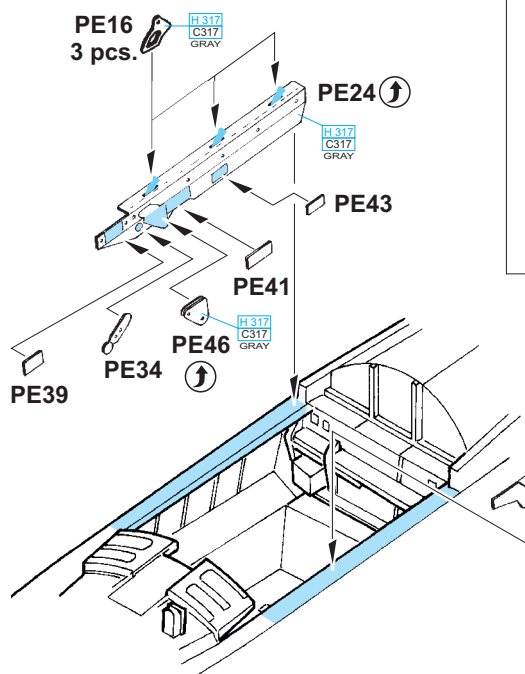

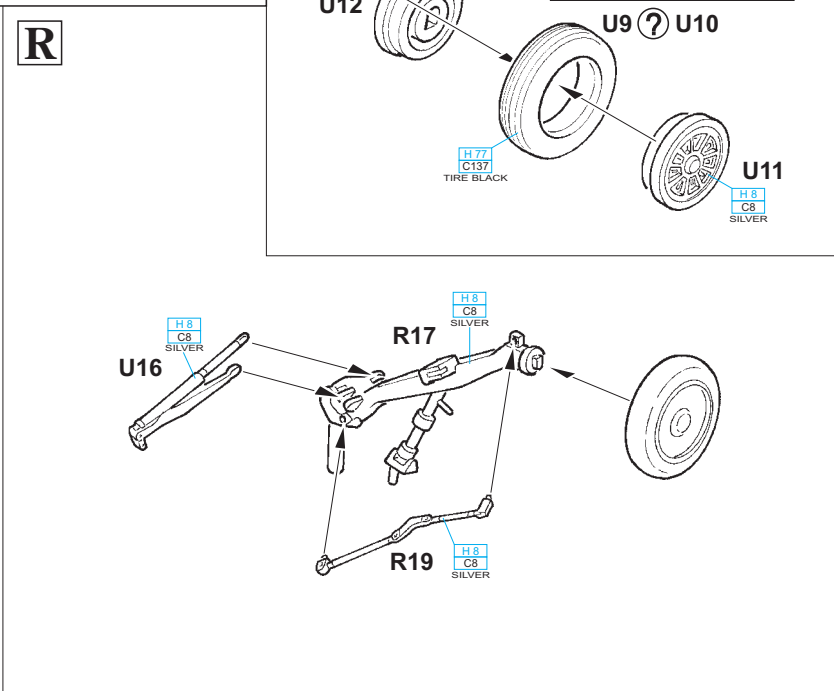
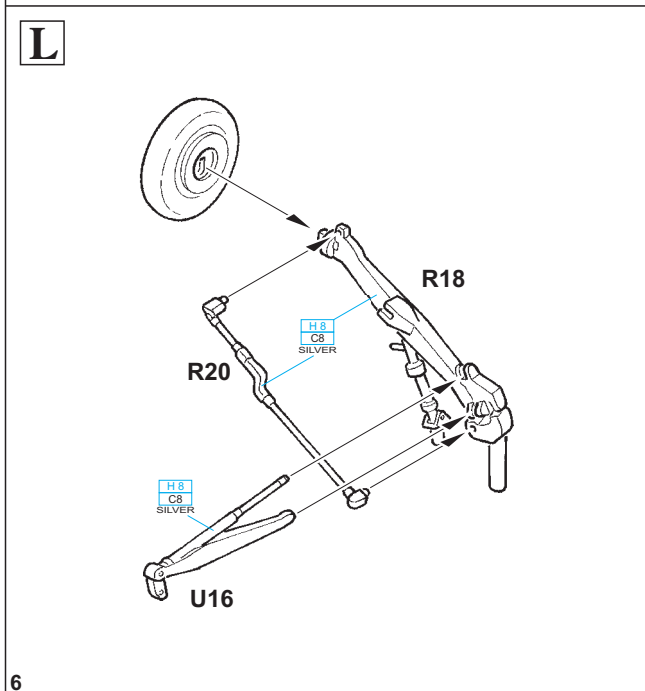
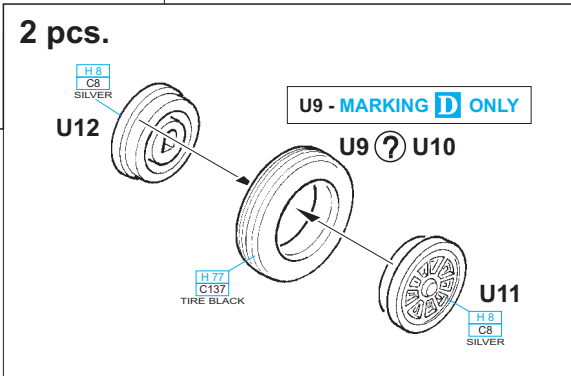
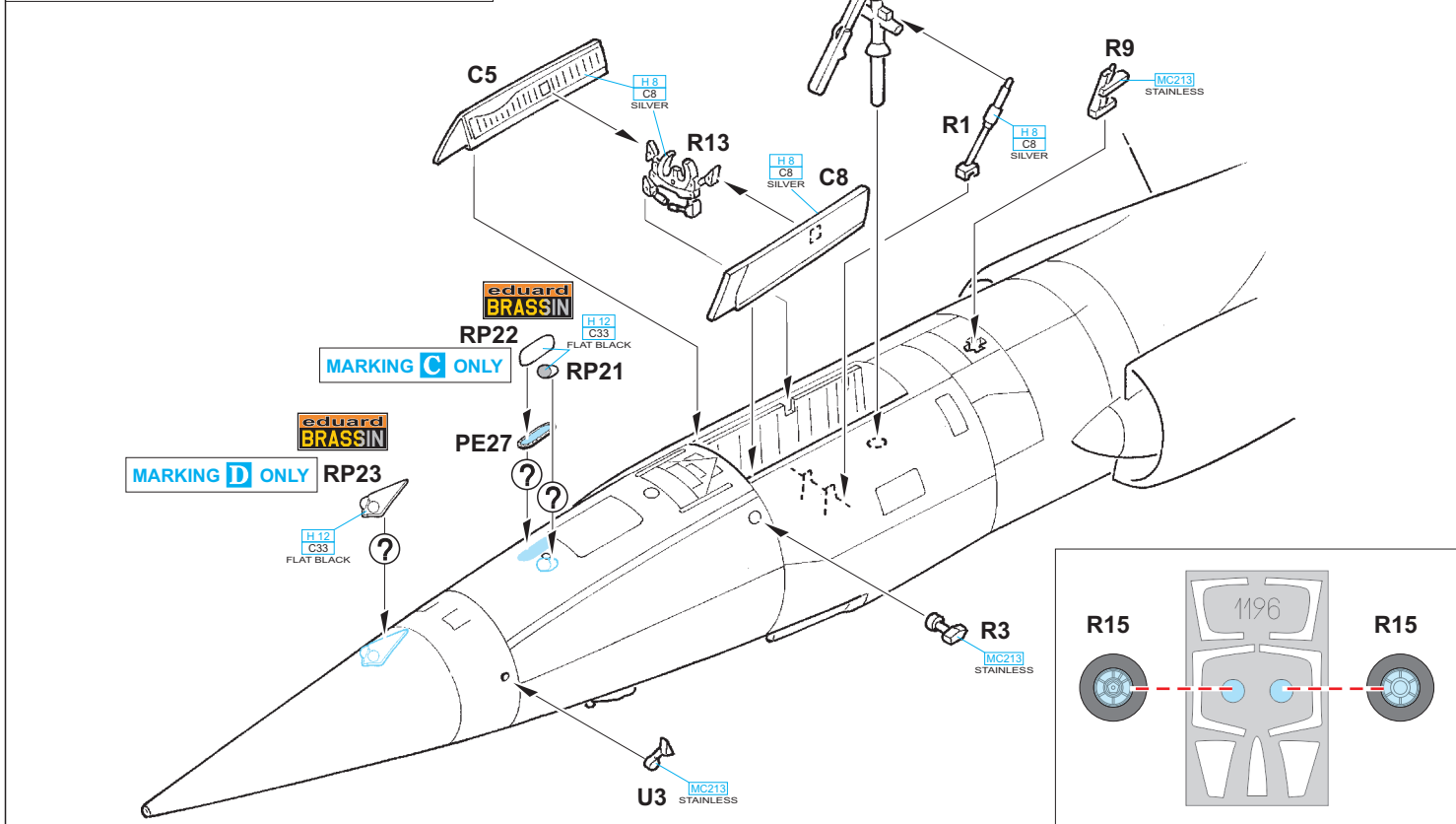
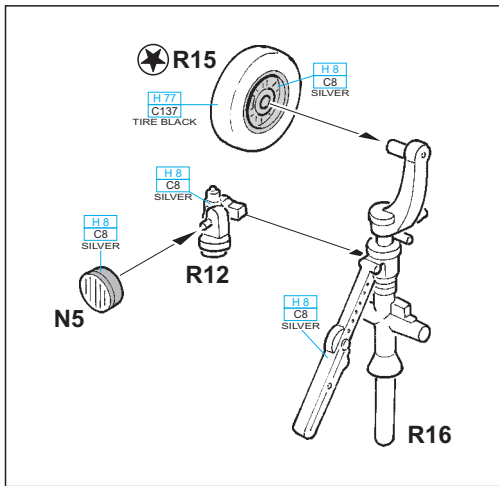

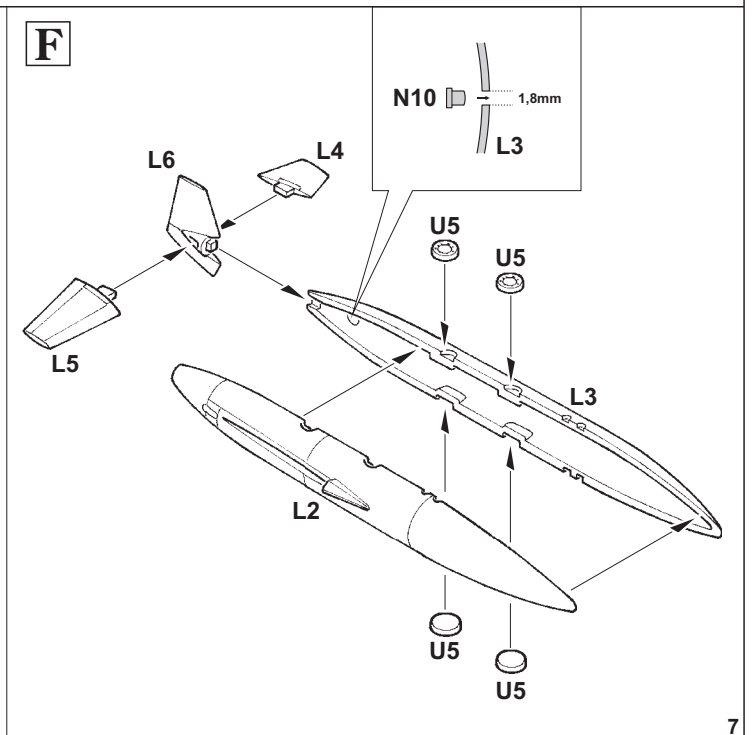
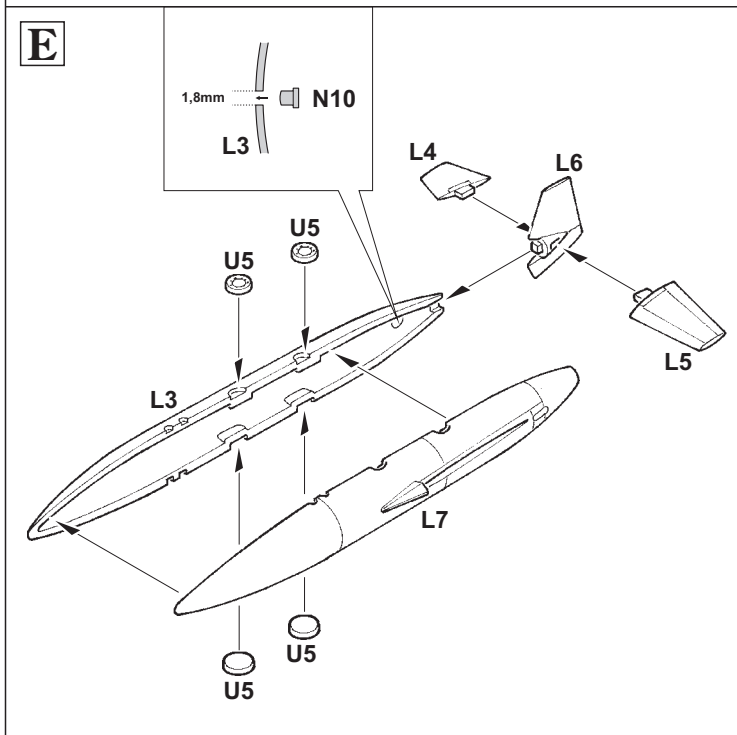
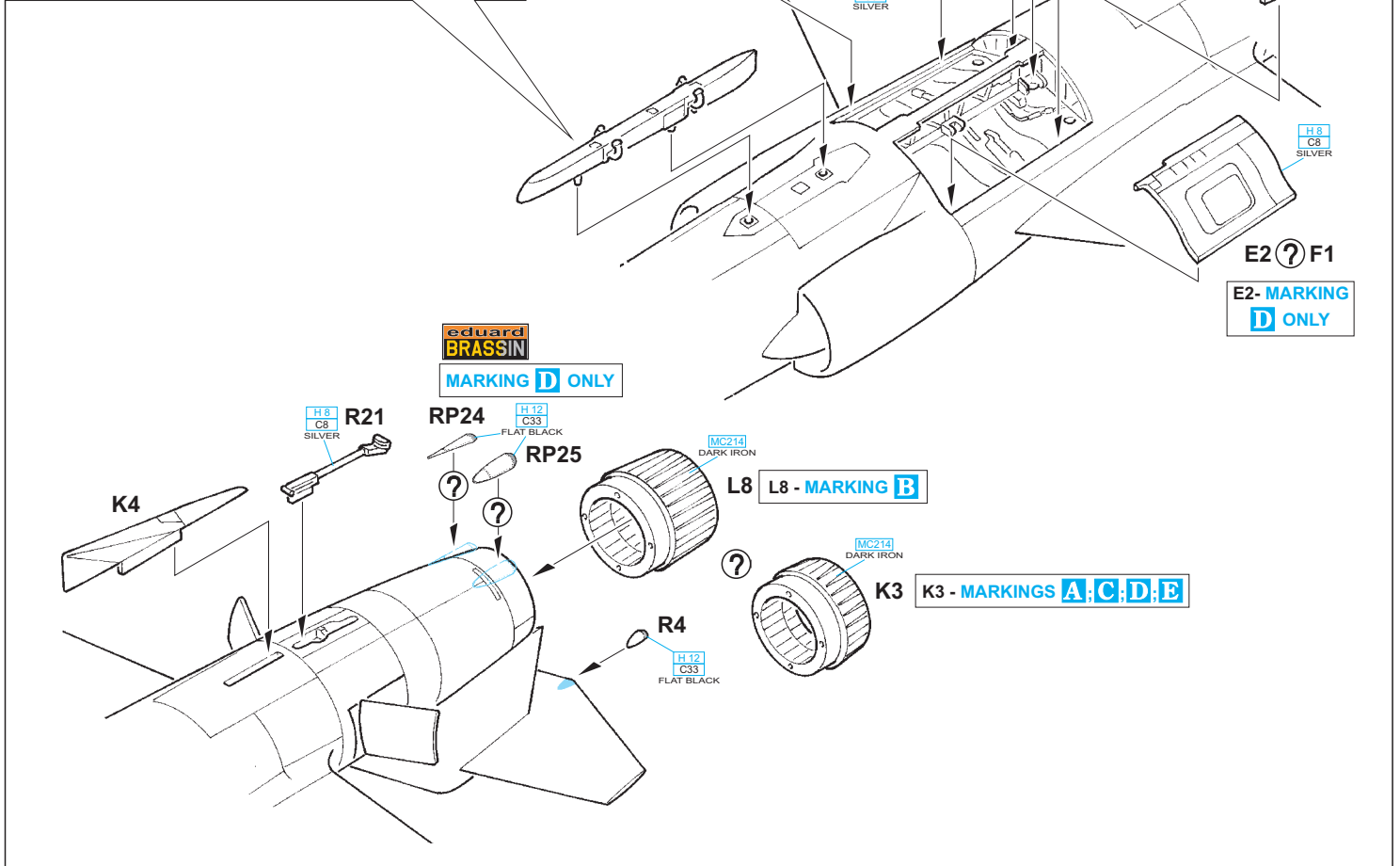
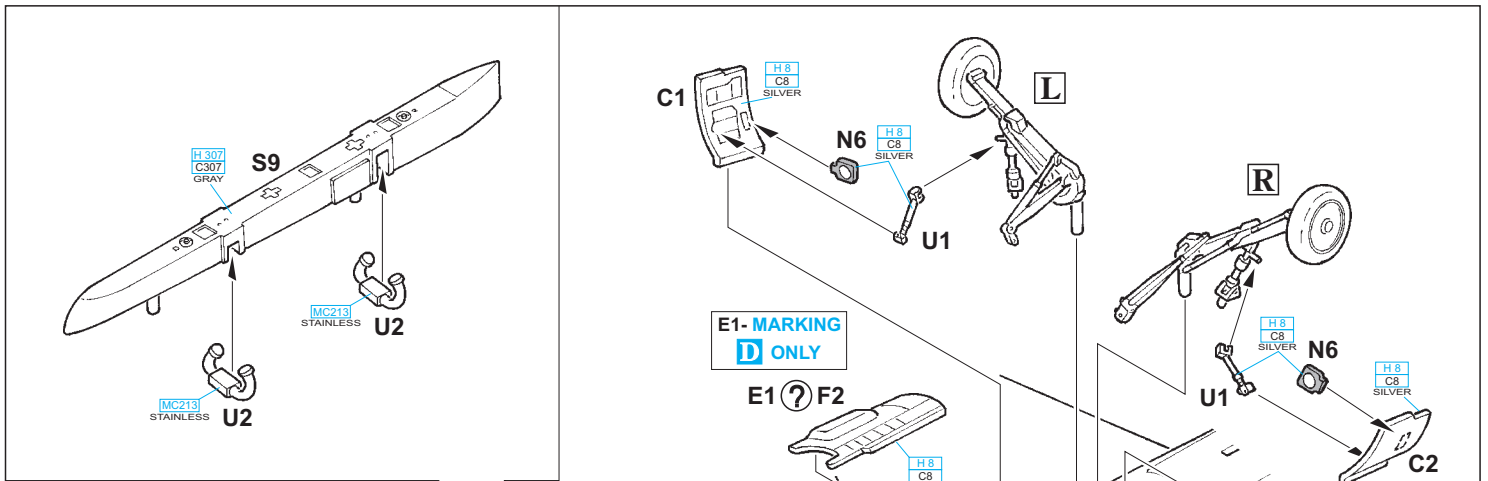

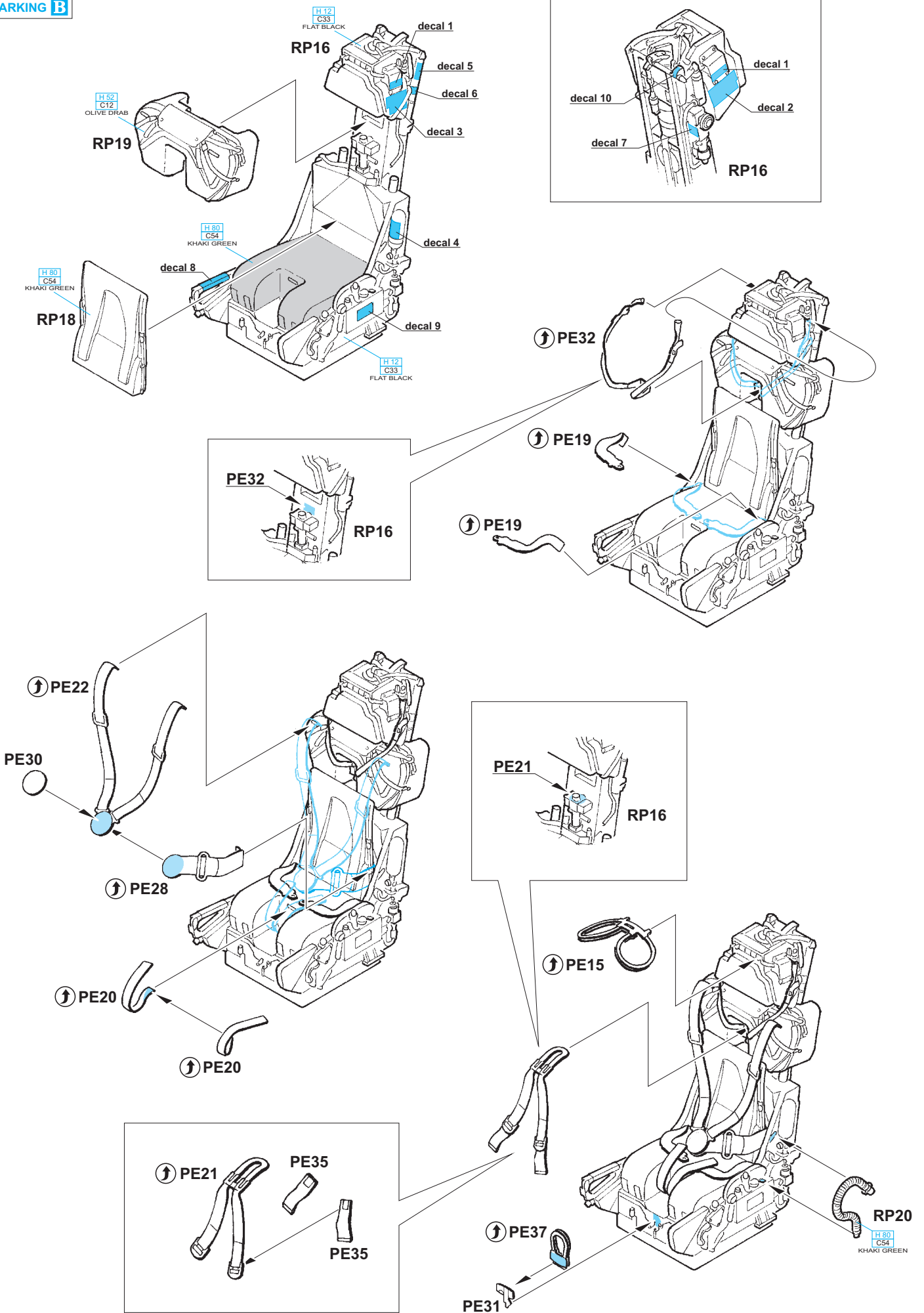



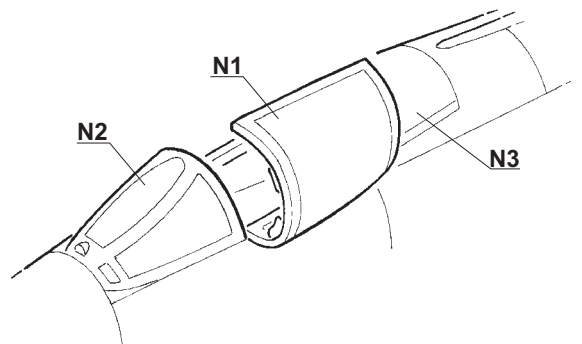
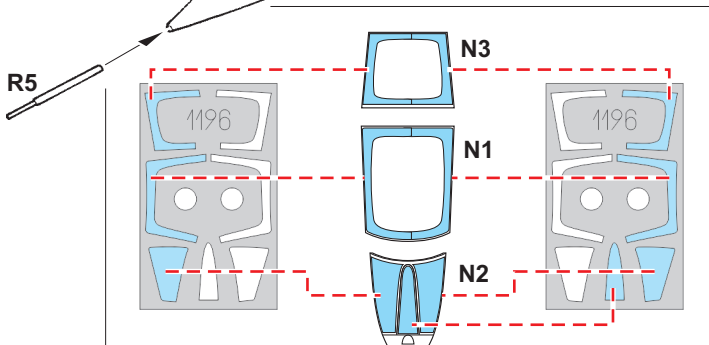
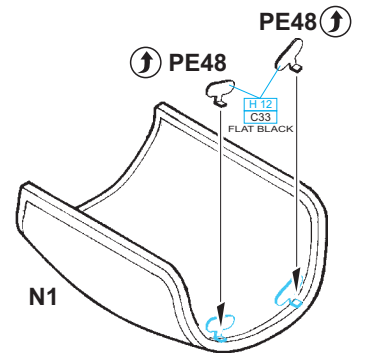
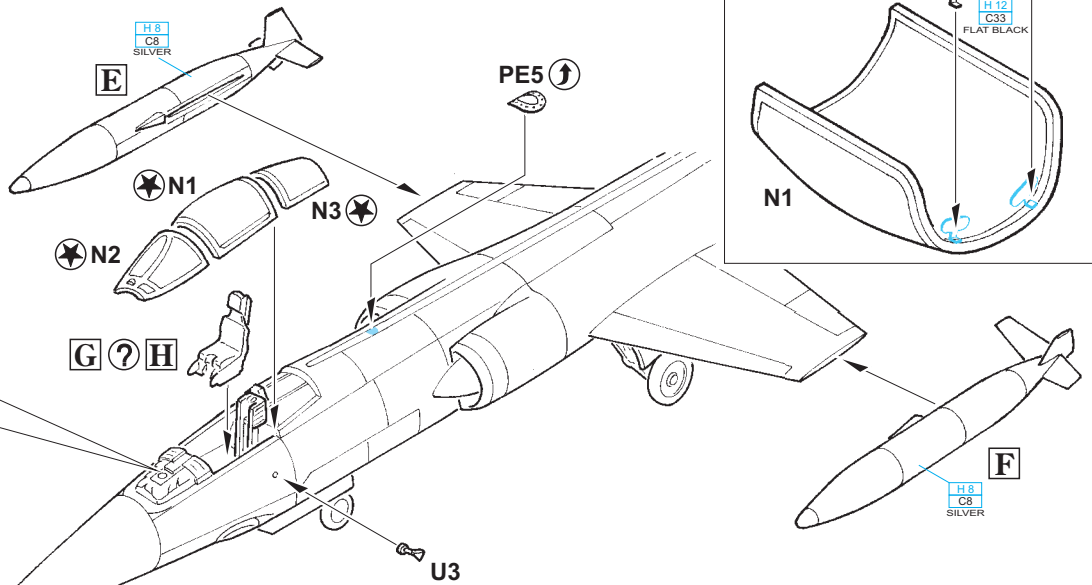
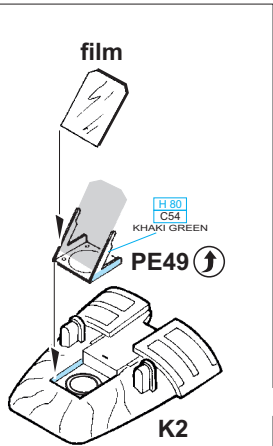
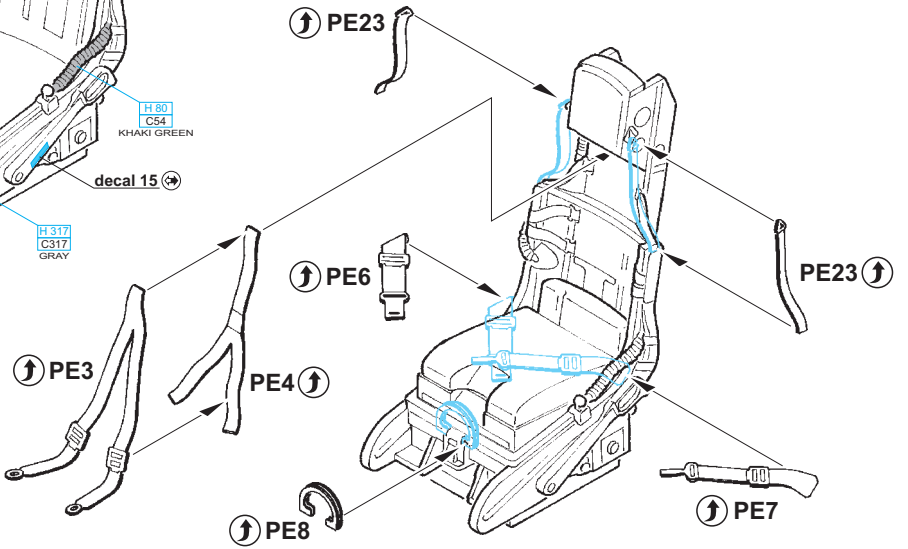
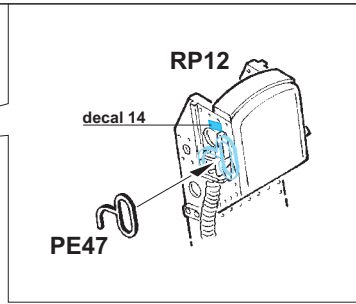
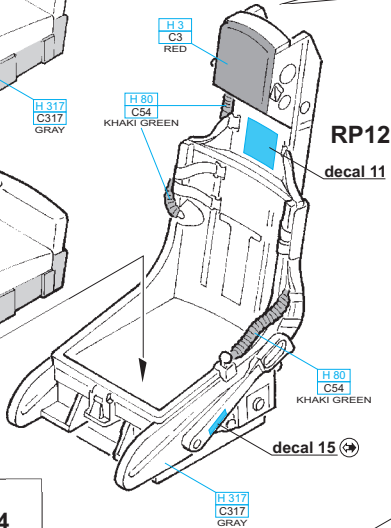
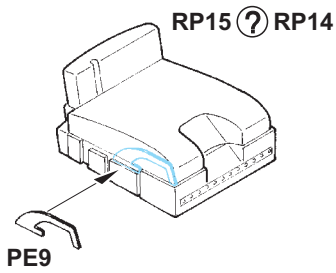
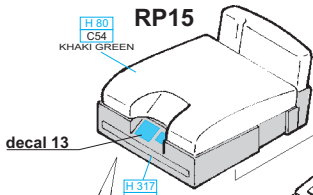
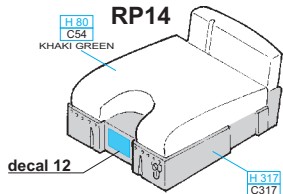

# A c/n 683C-4025, 331st Squadron, Royal Norwegian Air Force, Bodø Air Base, late 60s / early 70s

Manufactured by Lockheed, this Starfighter was ferried to Norway aboard the USS Fiedler. The ship anchored off Norway on October 26, 1963. This aircraft was coded FN-K and assigned to 331st Squadron. The new code – 625 – appeared on the F-104's fuselage in September, 1972. '625' was written off two years later. On September 15, 1974, it crashed while on approach to Bodø Air Base. The pilot managed to use the ejection seat but was unfortunately killed when his C-2 seat failed to separate. The aircraft was manufactured under the designation RF-104G but was fully armed and delivered to the Norwegian Air Force configured as an F-104G.

ČESKOU VERZI TEXTU NALEZNETE NA  
[www.eduard.com/s/1196](http://www.eduard.com/s/1196)

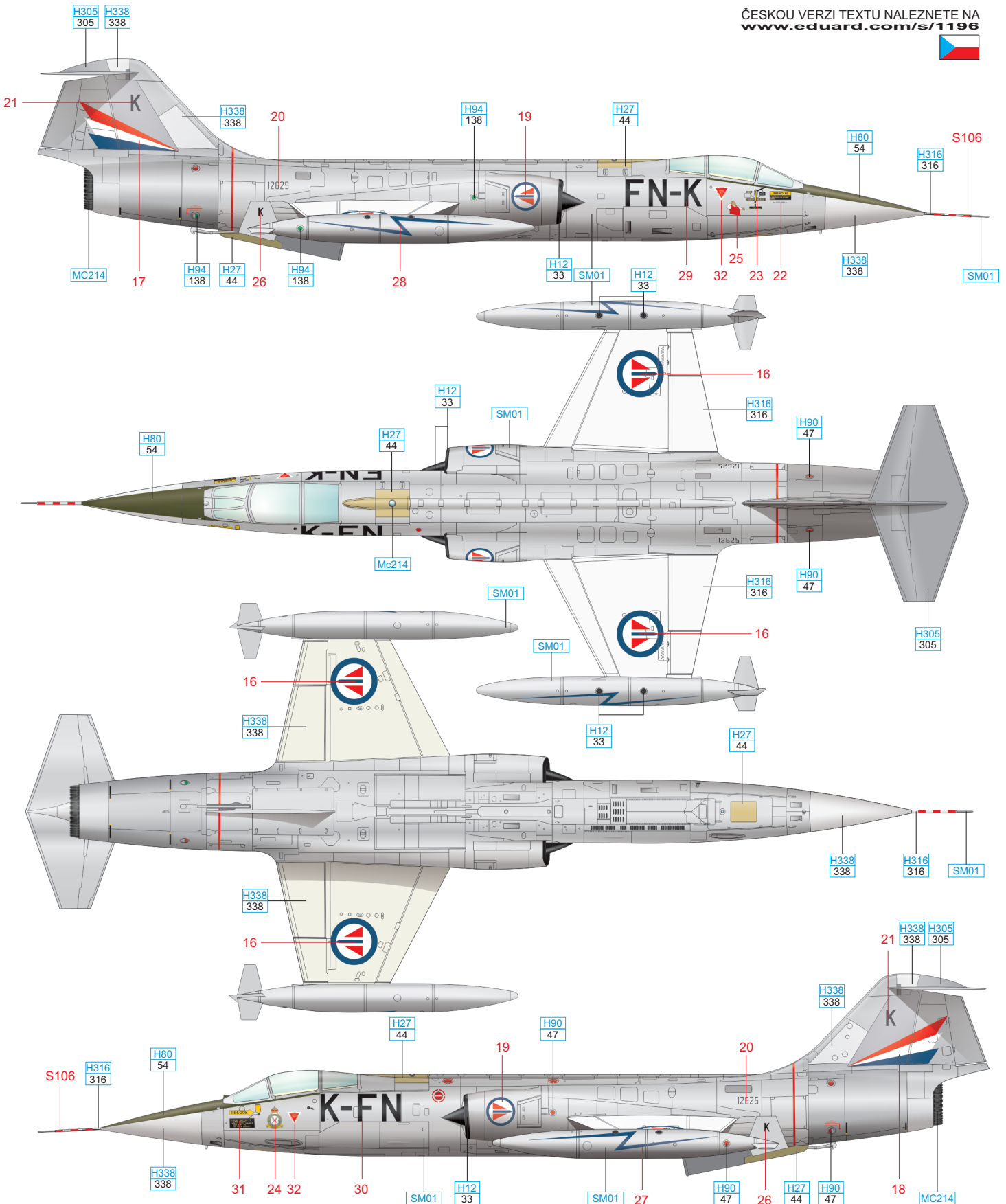

LIGHT GRAY	H338 338	DARK IRON	MC214	CLEAR GREEN	H94 138	TAN	H27 44	GRAY	H305 305
SILVER	SM01	WHITE	H316 316	BLACK	H12 33	CLEAR RED	H90 47	KHAKI GREEN	H80 54



# B c/n 683D-7037, 192nd Filo, Turkish Air Force, Balikesir Air Base / Fairford, 1991

This aircraft was assembled by Messerschmitt at their Manching facility with parts manufactured by Lockheed and made its maiden flight on November 5, 1962. It was flown by the following German squadrons - JaboG 33, JaboG 36, JaboG 32 and JaboG 34 and underwent many repairs and upgrades. Turkey bought it in late 1985. From May 1988, the aircraft served with 192nd Filo at Balikesir Air Base. It was withdrawn on January 31, 1994, stored at Dyarbakir AB and likely subsequently scrapped.

ČESKOU VERZI TEXTU NALEZNETE NA  
[www.eduard.com/s/1196](http://www.eduard.com/s/1196)



WHITE	H316 316	H338 338
LIGHT GRAY	H338 338	
DARK IRON	MC214	
BROWN	H310 310	
CLEAR GREEN	H94 138	
ORANGE	H14 59	
TAN	H27 44	
GRAY	H311 311	
GREEN	H303 303	
DARK GREEN	H309 309	
BLACK	H12 33	
SILVER	SM01	
CLEAR RED	H90 47	
KHAKI GREEN	H80 54	

**C** c/n 683-8331, Flown by Capt. Hans van der Werf, 312th Squadron RNLAF, Twente Enschede Airport, September 15, 1979

This aircraft, decorated with a shark mouth, was displayed during an open house at Twente Enschede Air Base on September 15, 1979. It was flown by the famous Dutch pilot Capt. Hans van der Werf. The Fokker built Starfighter served with No. 312 Squadron as can be gleaned from the squadron badge on the fin. The 315th Squadron badge – the lion - is painted on the left side of the tail as well.

ČESKOU VERZI TEXTU NALEZNETE NA [www.eduard.com/s/1196](http://www.eduard.com/s/1196)

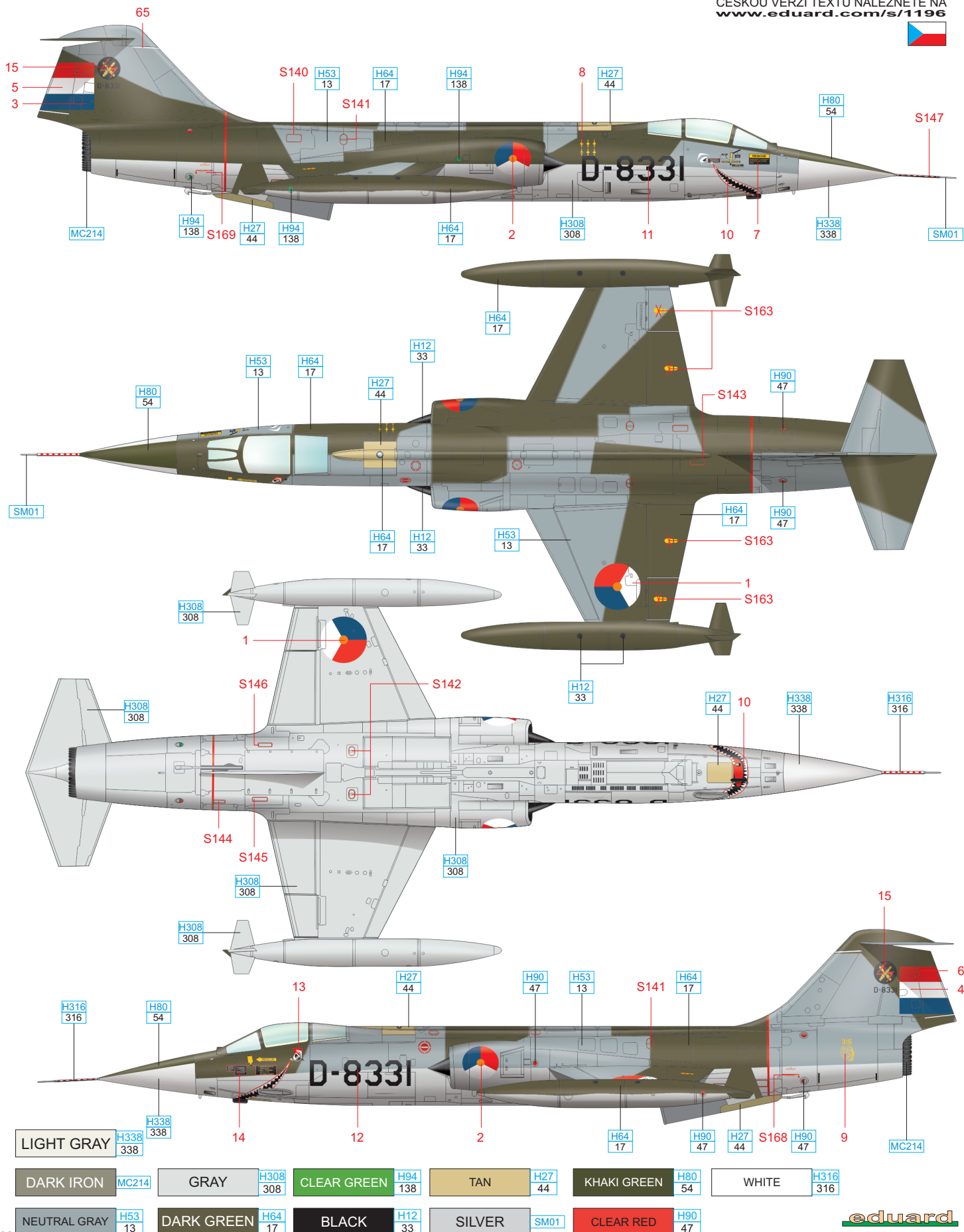

LIGHT GRAY	H338 338	GRAY	H308 308	CLEAR GREEN	H94 138	TAN	H27 44	KHAKI GREEN	H80 54	WHITE	H316 316
NEUTRAL GRAY	H53 13	DARK GREEN	H64 17	BLACK	H12 33	SILVER	SM01	CLEAR RED	H90 47		

# D c/n 683A-1199, Royal Canadian Air Force, Twente Air Base, the Netherlands, May, 1976

Manufactured by Canadair, this Starfighter made its first flight on August 19, 1963. The RCAF accepted it on December 15, 1963 and assigned it to No. 430 Squadron. This aircraft was involved in the Tactical Weapons Meet that took place in May, 1976 at Twente air base in the Netherlands. It wore colourfull fuel tanks for this occasion. It was stricken off charge on March 6, 1986 and sold to Turkey. Finally, the aircraft found its way to the Military Air Museum at Krumovo Airport, Plovdiv.

ČESKOU VERZI TEXTU NALEZNETE NA  
[www.eduard.com/s/1196](http://www.eduard.com/s/1196)

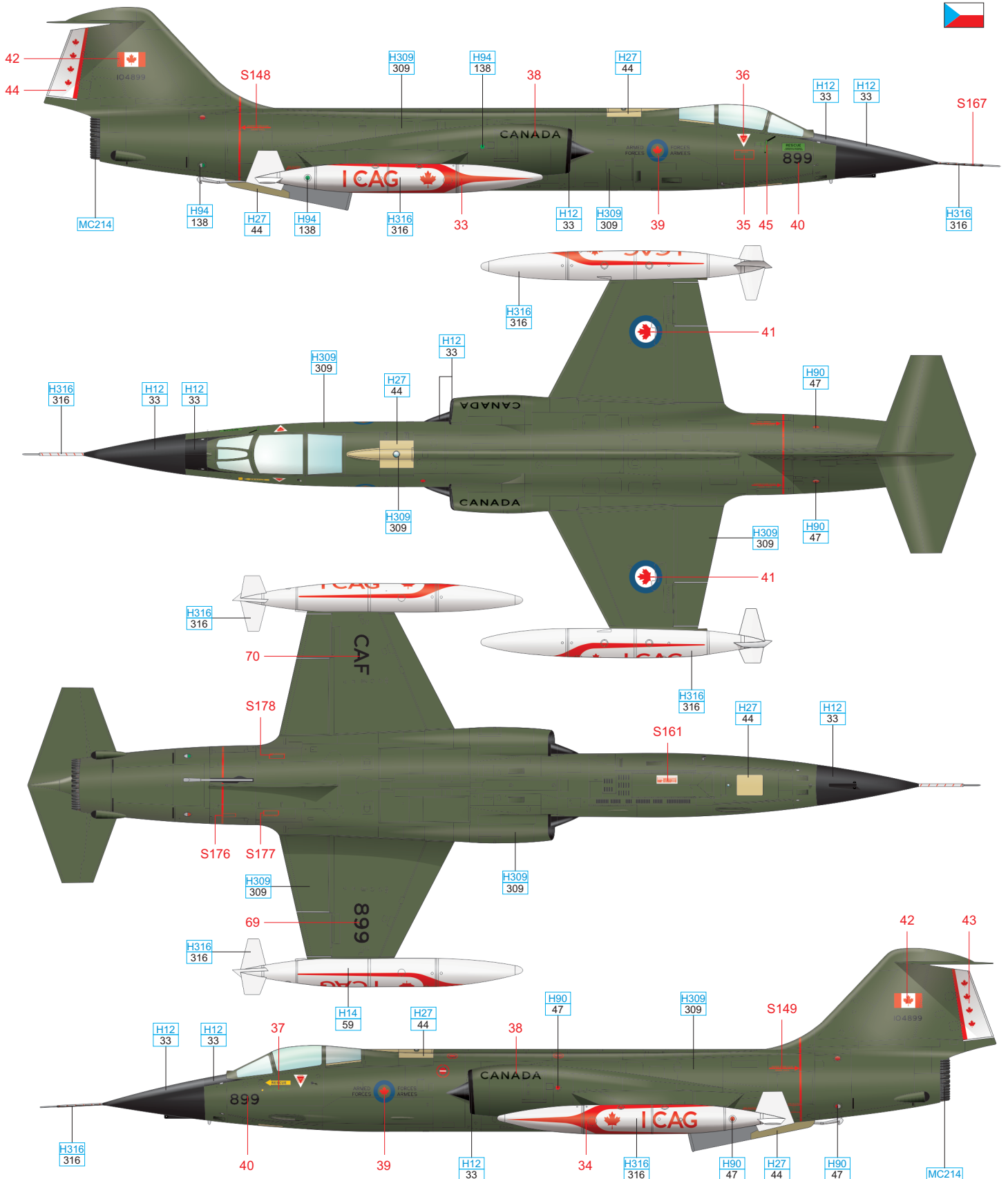

DARK IRON	MC214	WHITE	H316 316	CLEAR GREEN	H94 138	TAN	H27 44
GREEN	H309 309	BLACK	H12 33	CLEAR RED	H90 47	SILVER	SM01

# E c/n 683-9079, 350th Squadron, 1st Wing, Belgian Air Force

This aircraft was manufactured by SABCA. In May, 1964, it was delivered to the Belgian Air Force and assigned to No. 350 Squadron. It served with this squadron till December 21, 1979 when retired and handed over to the Technical School in Saffraanberg. Up to October, 2010, it was employed as an instructional airframe. In the same month, it departed the technical school and was ferried to Kleine Brogel Air Base and stored. The Belgian Air Force flew a total of 101 F-104G and 12 TF-104Gs.

ČESKOU VERZI TEXTU NALEZNETE NA  
[www.eduard.com/s/1196](http://www.eduard.com/s/1196)

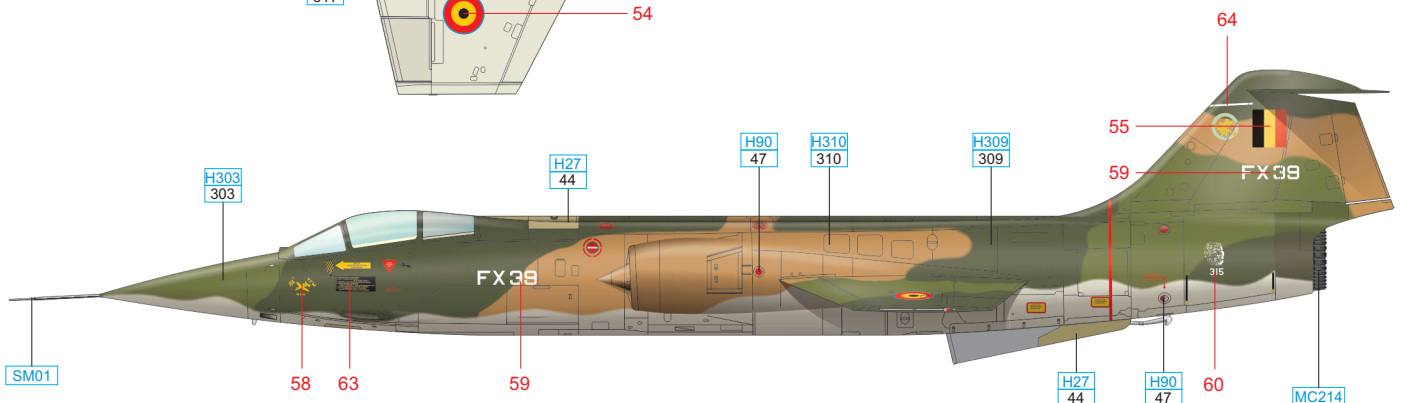
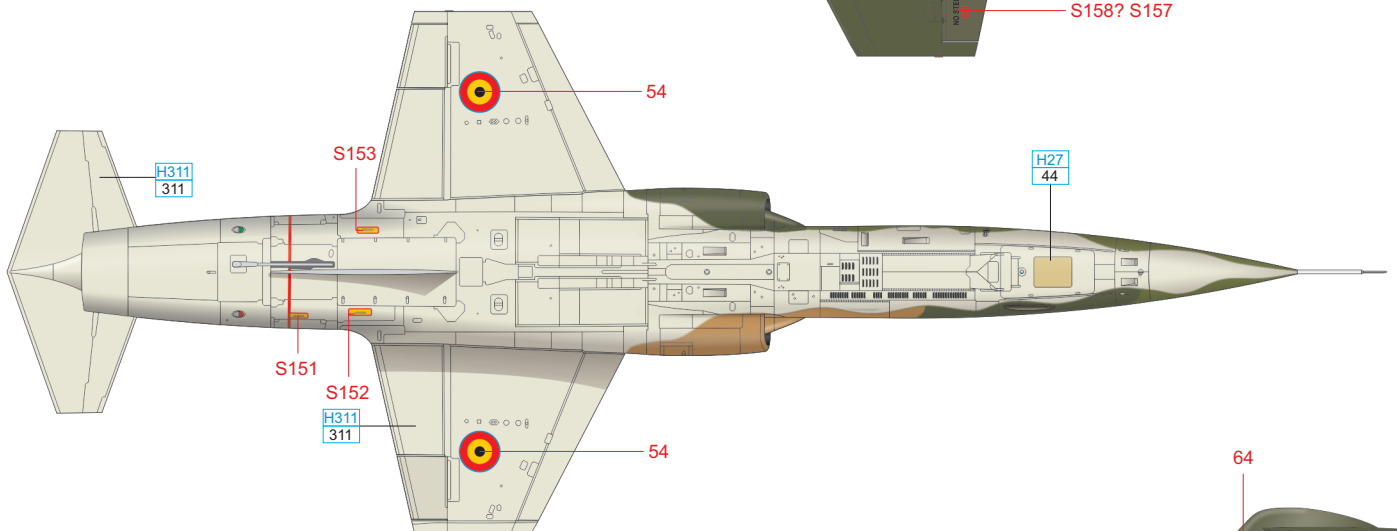
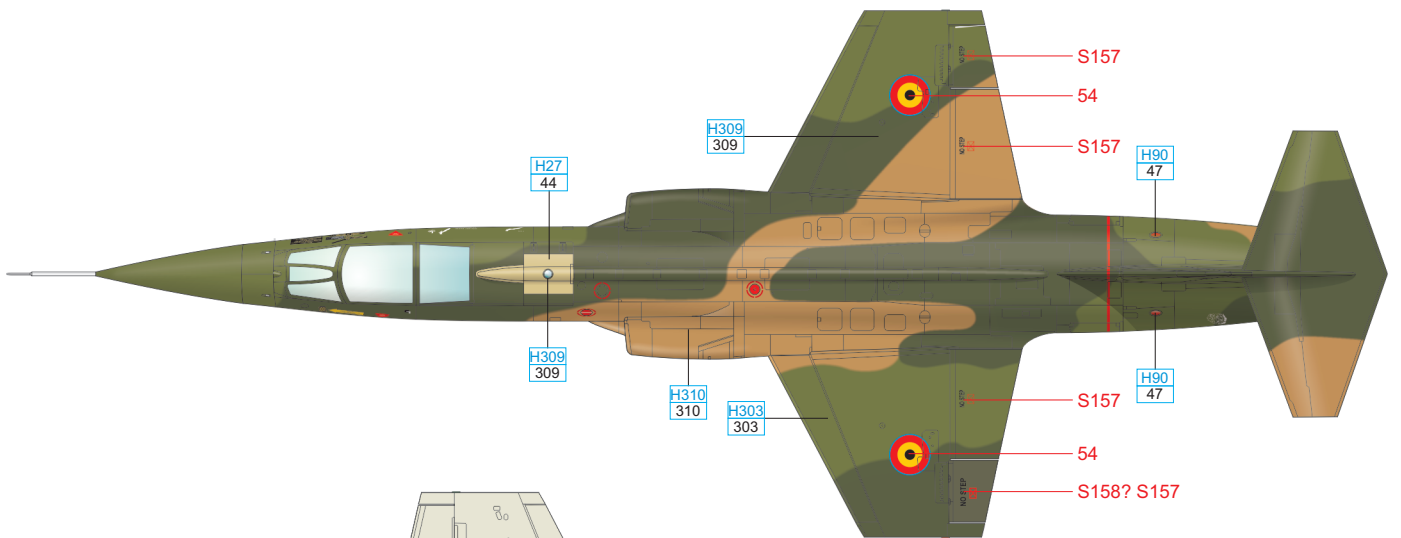
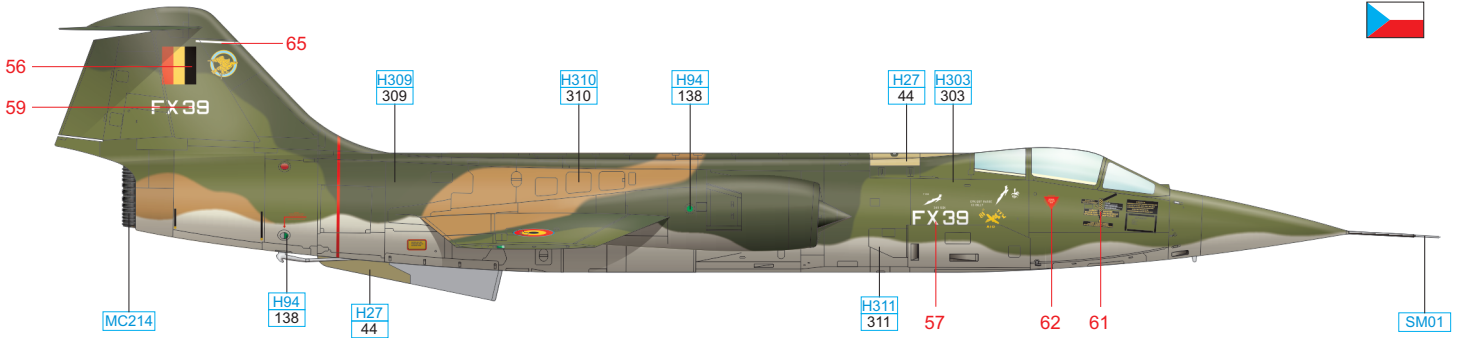

DARK IRON	MC214	BROWN	H310 310	CLEAR GREEN	H94 138	TAN	H27 44	GRAY	H311 311
GREEN	H303 303	DARK GREEN	H309 309	BLACK	H12 33	SILVER	SM01	CLEAR RED	H90 47

